

***CABLE REEL HOSE REEL***







**ZENDO**



# CABLE REEL HOSE REEL

## ENDO CABLE REEL and HOSE REEL

### LINE UP

					
<b>WHR type (Low pressure double winding)</b>	<b>HR type (Standard)</b>	<b>WORY type (High pressure double winding)</b>	<b>CRL type (Standard)</b>	<b>CRF type (For indoor, Small)</b>	<b>CRE type (Long stroke)</b>
<b>Spring-Driven</b>					
<b>Hose reel</b>			<b>Cable reel</b>		

### CONTENTS

Cable reel Specifications .....	3	CRF type Cable reel (For indoor, Small) .....	8
Application Examples .....	4	CRL type Cable reel (Standard) .....	9
Questionnaire for Cable reel .....	5	CRE type Cable reel (Long stroke) .....	15
Questionnaire for Hose reel .....	6	CRH type Cable reel (Center impeller type) .....	17
Terminology Definitions .....	7		
Applications and Calculation of Required reel torque .....	7		
Calculation of Effective reel torque .....	7		



**CRH type  
(Center impeller  
type)**



**Torque motor  
type**



**Inverter-driven  
motor type**

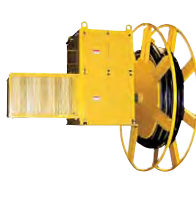

**Servomotor  
type**



**Contorq  
type**



**Geared motor  
type**

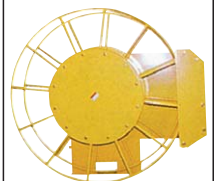

**Hydraulic  
motor  
type**

**Motor-Driven**

**Hose reel**

<b>Totally-enclosed torque motor Cable reel</b> .....	19
<b>Torque motor Cable reel</b> .....	21
<b>Inverter driven motor Cable reel</b> .....	25
<b>Servomotor Cable reel</b> .....	25
<b>Contorq type Cable reel</b> .....	27
<b>Geared motor Cable reel (Indoor)</b> .....	31
<b>Hydraulic motor Cable reel</b> .....	33

<b>WHR type Hose reel (Low pressure double winding)</b> .....	34
<b>HR type Hose reel (Standard)</b> .....	35
<b>WORY type Hose reel (High pressure double winding)</b> .....	37

<b>Special Accessories</b> .....	39
<b>Special Specifications and Applications</b> .....	41
<b>Main Components of a Cable reel</b> .....	43
<b>Cable and Hose data</b> .....	44

# VARIOUS APPLICATIONS for ENDO REEL

- Simple Construction of Wiring and Piping
- Fuss-free maintenance
- Safety use for indoor and outdoor
- Superiority of cable winding operation (in every speed)
- A great variety of models in various applications

## REEL SPECIFICATIONS

### 1. Machine specification

- Standard travel/lift speed is less than 40m/min. If over 40m/min is required, please contact your local ENDO distributors or us.  
NOTE: Some applications are applied less than 30m/min.
- Operation frequency shall be 50 times a day. (Payout and Retract)

### 2. Slip ring specification

- Basic usage is on an alternating current (AC). If you require a direct current (DC), please contact your local ENDO distributors or us. (Due to risks of spark or heat, AC slip ring is unusable for a Lifting Magnet use.)
- Please do not use a cable reel with a power cable for an inverter-driven motor at following conditions:
  - In case that the 400V class cable reel is connected to the secondary side of the inverter controller (between the controller and the motor)
- If signal conductors are used with power conductors in a same cable, the malfunctioning may occur.
- Silver brush specification:

Rated voltage	AC250V / DC100V
Rated current	15A ~ 16P 10A ~ 32P
Contact resistance changes	10mΩ (at 60 r.p.m)
Applications	Sequencer, Thermocouple, Load cell, Phone line, etc.

### 3. Painting specification

- Standard painting ... Thermosetting polyester resin coating  
(Acrylated alkyd resin coating for some models)
- Painting color ..... Munsell 2.5Y 7/10 (Yellow)

### 4. Circumstances

- Ambient temperature ..... Spring type, Hydraulic Motor type ..... -10°C ~ +50°C  
Electric motor type ..... -10°C ~ +40°C
- Waterproof ..... Rain-proof, available for outdoor use (CRF/Geared motor type are for indoor use only)
- Corrosion resistance ..... Contact your local ENDO distributors or us in each case.  
(for against seawater, chemicals, etc.)



# Application examples

**Gantry crane ※**

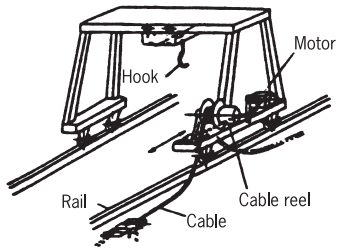

**Moving instruments ※**

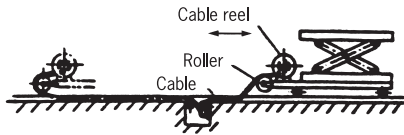

**Mobile car ※**

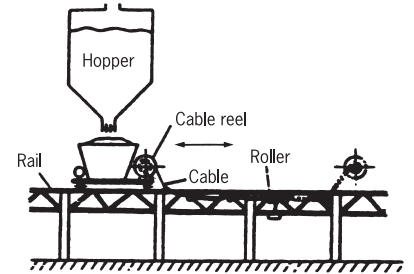

**Air hoist, Electric hoist**

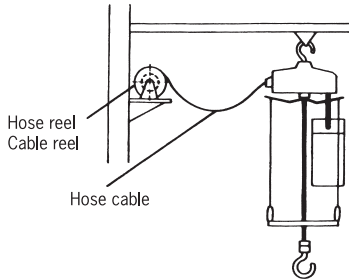

**Extendable conveyors**

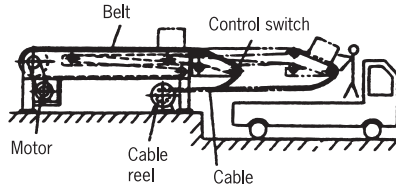

**Concrete mixing-plant**

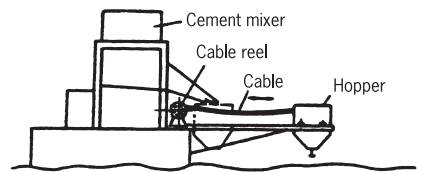

**Factory elements**

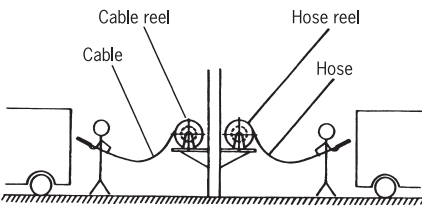

**Car-washing machine**

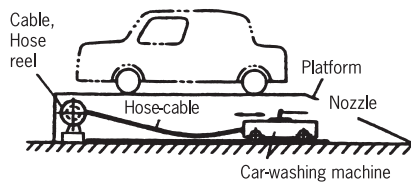

**Stage lighting system**

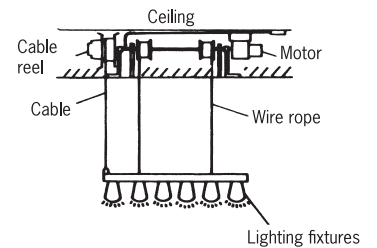

**Lifting magnet**

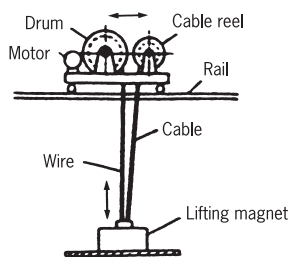

**Lifting magnet crane**

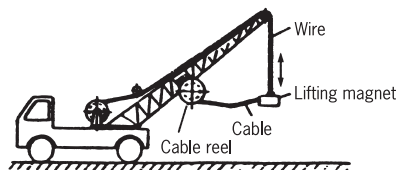

**For winding a pendant switch**

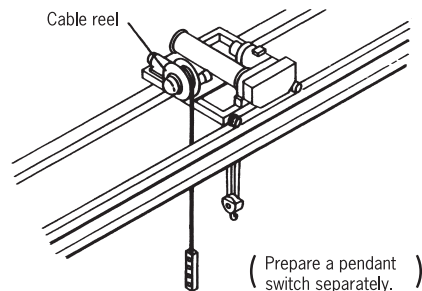

※ Two-way payout is available. The travel distance will be as twice as the cable length in this case.

# Questionnaire for Cable reel

Please fill out the form and contact us to place an order or an inquiry.



## Questionnaire

1. Cable type ( ) /manufacturer ( )
2. Conductor cross-section ( ) mm<sup>2</sup>
3. Number of conductors ( ) c
4. Outside dia ( ) ∅mm
5. Weight ( ) kg/m
6. Current ( ) A
7. Travel length ( ) m, Installation height ( ) m
8. Maximum travel/lift speed ( ) m/min, acceleration ( ) sec
9. Application ( ) \* select from the list below.
10. Operation frequency ( ) times/day \* ( ) hours/day
11. Environment (Indoor / outdoor) \* Dust atmosphere ( Yes / No )
12. Ambient temperature ( ) °C
13. Purpose for use ( ) e.g. Gantry crane, Trolley, Lighting system, etc.

\* In case of Geared motor type, Torque motor type, Contorq motor type:

Voltage ( ) V / frequency ( ) Hz

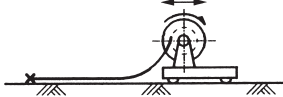
14. Delivery ( with Cable / without Cable )
15. Quantity ( )
16. Delivery requirement ( )

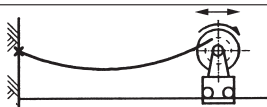
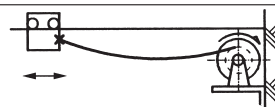
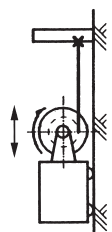
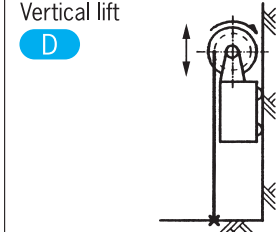
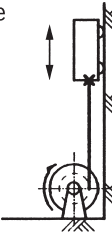
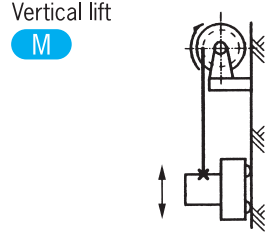
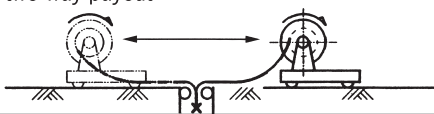
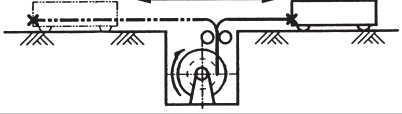
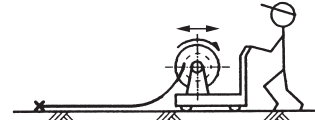
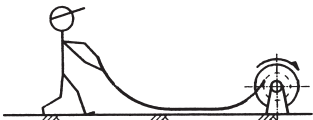
Mobile application		Stationary application	
Horizontal retrieve <b>A</b> 	Horizontal drag <b>G</b> 		
Horizontal stretch <b>B</b> 	Horizontal stretch <b>H</b> 		
Vertical retrieve <b>C</b> 	Vertical lift <b>D</b> 	Vertical retrieve <b>K</b> 	Vertical lift <b>M</b> 
Horizontal retrieve, two way payout <b>E</b> 		Horizontal drag, two way payout <b>N</b> 	
Horizontal retrieve <b>F</b> 		Horizontal drag <b>P</b> 	

# Questionnaire for Hose reel

Please fill out the form and contact us to place an order or an inquiry.





## Questionnaire

1. Hose type ( ) /manufacturer ( )
2. Inside dia. ( )  $\varnothing$  mm
3. Outside dia. ( )  $\varnothing$  mm
4. Bending radius ( ) mm
5. Weight ( ) kg/m
6. Fluid ( )
7. Working pressure ( ) Mpa ( ) kgf/cm<sup>2</sup>
8. Pressing winding ( Yes / No )
9. Travel distance ( ) m, Installation height ( ) m
10. Maximum travel/lift ( ) m/min, acceleration ( ) sec
11. Operation frequency ( ) time/day ( ) hours/day
12. Application ( ) \* select from the list below.
13. Environment (Indoor / outdoor) \* Dust atmosphere ( Yes / No )  
\* Ambient temperature ( ) °C
14. Purpose for use ( ) e.g. Crane, Trolley, Bucket, etc.

\* In case of Geared motor type, Torque motor type, Contorq motor type:

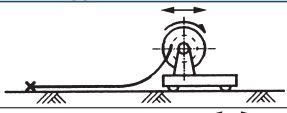
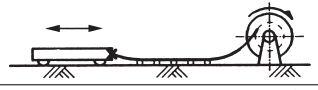
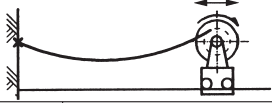
Voltage ( ) V / frequency ( ) Hz

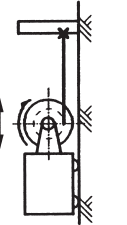
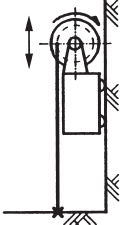
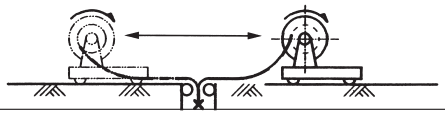
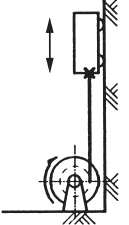
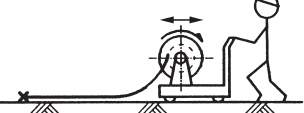
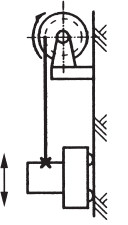
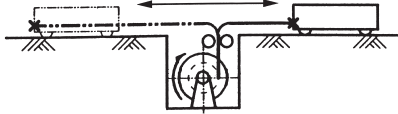
15. Delivery ( with Cable / without Cable )
16. Quantity ( )
17. Delivery requirement ( )

Mobile application		Stationary application	
Horizontal retrieve <b>A</b>		Horizontal drag <b>G</b>	
Horizontal stretch <b>B</b>		Horizontal stretch <b>H</b>	
Vertical retrieve <b>C</b>		Vertical lift <b>D</b>	
Horizontal retrieve, two way payout <b>E</b>		Vertical retrieve <b>K</b>	
Horizontal retrieve <b>F</b>		Vertical lift <b>M</b>	
		Horizontal drag, two way payout <b>N</b>	
		Horizontal drag <b>P</b>	

# Terminology definitions

**Forward winding** : Clockwise winding looking from the bracket side.

**Reverse winding** : Counterclockwise winding looking from the bracket side.

**Forward setting** : The installation plate (base plate) is located under the drum.

**Reverse setting** : The installation plate (base plate) is located on the opposite side of the drum.

**C-class ground connection work** : The ground connection that connects the cable to the metal part to avoid an electrostatic charge, and is less than 10 ohm ground resistance.

**Dead turns** : The 2-3 turns of cable wrapped around the drum in addition to the used winding length.

**Initial spring turns** : The applied initial tension to the spring. The initial tension is required for winding the cable on the drum properly.

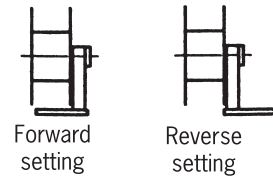
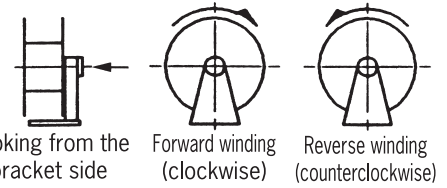

# Applications and calculation of required reel torque

Mobile application	Stationary application
<b>Horizontal retrieve</b> $fe > (w \times \ell) \times 9.807$ $\ell \doteq 2h$	<b>Horizontal drag</b> $Fe > w \times (\ell + L^1) \times \mu \times 9.807$ With rollers $\mu \doteq 0.2 \sim 0.1$ Rubber and concrete surface $\mu \doteq 0.7 \sim 0.6$
<b>Horizontal stretch</b> $Fe > \frac{w \times L^2 \times 9.807}{8 \times S}$ Roller guide set in the middle of the cable helps cable winding.	<b>Horizontal stretch</b> $Fe > \frac{w \times L^2 \times 9.807}{8 \times S}$ Roller guide set in the middle of the cable helps cable winding.
<b>Vertical retrieve</b> $fe > w \times 9.807$ Reel torque is required to wind in cable / hose hardness enough.	<b>Vertical retrieve</b> $fe > w \times 9.807$ Reel torque is required to wind in cable / hose hardness enough.
<b>Vertical lift</b> $Fe > (w \times L + \triangle) \times 9.807$ $\triangle =$ Accessory weight (kg)	<b>Vertical lift</b> $Fe > (w \times L + \triangle) \times 9.807$ $\triangle =$ Accessory weight (kg)
<b>Horizontal retrieve, two-way payout</b> Same calculation as horizontal retrieve above.	<b>Horizontal drag, two-way payout</b> Same calculation as horizontal retrieve above.

Fe=Effective max reel torque(N) fe=Initial reel torque(N) w=Weight(kg/m) L=Max operational cable length + extensions(m)  
 L<sup>1</sup>=Operational cable length(m) ℓ=Extension length(m) S=Cable sag(m)

# Calculation of effective reel torque

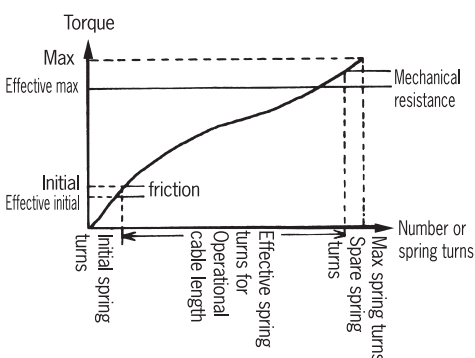

$$\text{Max spring tension} \cdots F(N)\{kgf\} = \frac{\text{Max torque}(N \cdot m)\{kgf \cdot m\}}{\text{Drum radius}(m)}$$

$$\text{Effective max reel torque} \cdots Fe(N)\{kgf\} = F \cdot \{(\text{Mechanical resistance} \doteq 0.15F) + (\text{Reel torque and spare spring turns of cable and hose} \doteq 0.15F)\} \doteq 0.7F$$

Initial reel torque  $\cdots fe(N)\{kgf\}$  varies depending on initial spring turns.  
 And initial spring turns depend on the application condition.

NOTE: 1. When selecting a model (over 4 poles of conductors, 1MPa working pressure, 40m/min travel/lift speed, etc.), please take into consideration of high mechanical stress.  
 2. When reel torque is required powerfully (vertical lift, horizontal stretch etc.), the reel torque must be less than 20N per 1mm<sup>2</sup>. If the reel torque would be over 20N, please use premium cables.

# CRF TYPE CABLE REEL

(For indoor, Small)

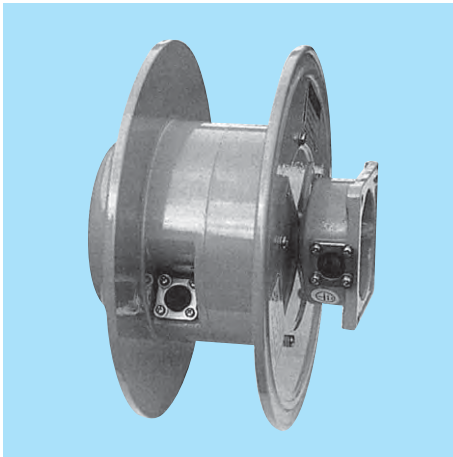

## Model description

**CRF-11032**

Spring type  
Drum cover dia.  
Drum width  
Flange type  
Cable reel

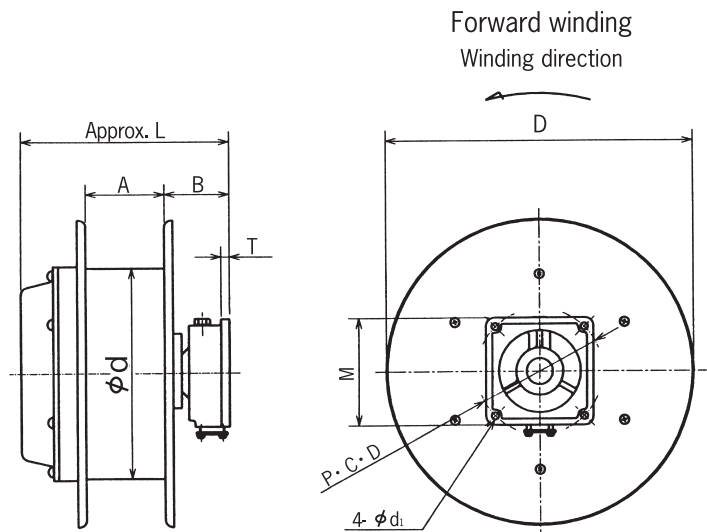

## Slip ring capacity (Rated voltage AC250V)

Rated current	Number of poles			
12A	3	4	6	8

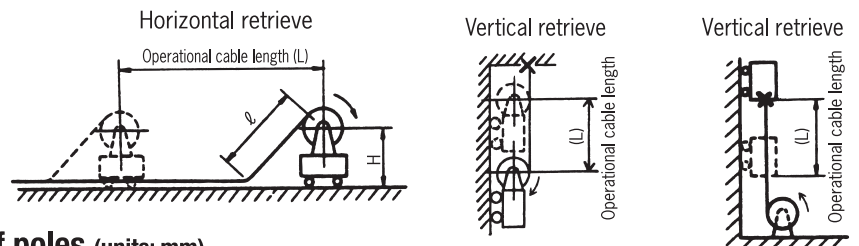

## Additional L length by the number of poles (units: mm)

Rated current	Number of poles			
	3	4	6	8
12A	0	0	24	40

## Specifications, Dimensions and Max operational cable length (Mobile application /Horizontal & Vertical retrieve, Stationary application / Vertical retrieve)

Model	Max Torque N·m{kgf·m}	Max spring tension N{kgf}	Max spring turns n	Operational cable length (L)(m)			Dimensions (mm)									Mass (kg)
				φ 11	φ 13	φ 14.5	D	d	A	B	L	M	P·C·D	T	d1	
CRF-11032	3.1{0.32}	39 {4.0}	22	12	12	7	275	160	90	55	189	102	120	10	7	8
CRF-1105-1	4.9{0.5}	60 {6.2}	17	7	6	5	240	160	90	55	189	102	120	10	7	8
CRF-1105	4.9{0.5}	60 {6.2}	17		8	7	275	160	90	55	189	102	120	10	7	8

NOTE: 1. Calculated at following conditions:

- ① Cable type ..... 2PNCT
- ② Applications ..... Mobile application /Horizontal & vertical retrieve, Stationary application / Vertical retrieve
- ③ Max travel/ lift speed ..... less than 40mm/min
- ④ Installation height ..... less than 0.5m

2. Deviations due to roller guides, non-straight cable payout, low ambient temperature, etc. are not calculated. When selecting a model, please take into consideration of high mechanical stress and harsh environment conditions.

3. For high speed or high operation frequency rate, please use premium cables.

4. Suffix -R on all model names identifies reverse winding.

5. For any special requirements, please contact us.



# CRL TYPE CABLE REEL

(Standard)

● Protective Structure ..... Approx.IP44

● CRL-2205 ~ 3A416W

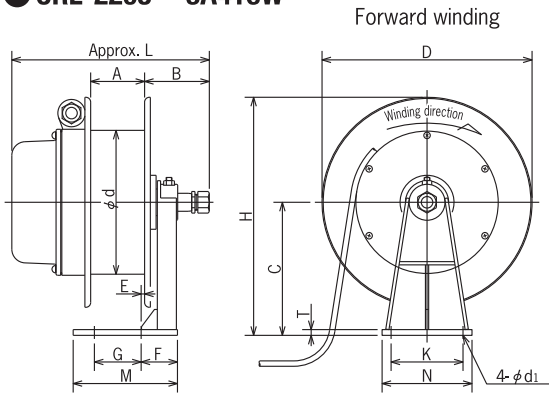

**Model description**  
**CRL-3A416W**

- Number of springs (No mark=1, W=2, T=3, F=4, V=5)
- Spring type
- Drum cover dia.
- Drum width (A: wide, M: narrow)
- Stand type
- Cable reel

● CRL-4M424 ~ 7875F

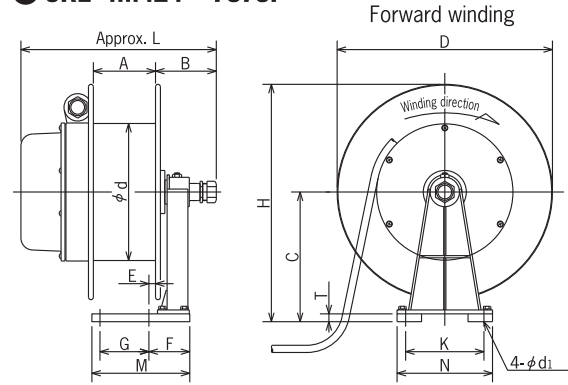

## Specifications and Dimensions

Model	Max torque N·m{kgf·m}	Max spring tension N{kgf}	Max spring turns n					
				D	d	A	B	C
CRL-2205	4.9{ 0.5}	49{ 5.0}	20	292	200	75	90	185
CRL-2A205W	4.9{ 0.5}	49{ 5.0}	39	292	200	110	90	185
CRL-2A210	9.8{ 1.0}	98{10.0}	20	292	200	110	90	185
CRL-2305	4.9{ 0.5}	49{ 5.0}	20	350	200	75	90	215
CRL-2A305W	4.9{ 0.5}	49{ 5.0}	39	350	200	110	90	215
CRL-3316	15.6{ 1.6}	132{13.5}	13	350	230	75	95	215
CRL-3A309W	8.8{ 0.9}	73{ 7.5}	38	350	230	110	90	215
CRL-3A316W	15.6{ 1.6}	132{13.5}	26	350	230	110	95	215
CRL-3409	8.8{ 0.9}	73{ 7.5}	19	440	230	75	90	260
CRL-3A409W	8.8{ 0.9}	73{ 7.5}	38	440	230	110	90	260
CRL-3A416W	15.6{ 1.6}	132{13.5}	26	440	230	110	95	260
CRL-4M424	23.5{ 2.4}	166{17.0}	13	440	280	127	124	265
CRL-4424W	23.5{ 2.4}	166{17.0}	26	440	280	165	124	265
CRL-4424T	23.5{ 2.4}	166{17.0}	39	440	280	165	124	265
CRL-4424F	23.5{ 2.4}	166{17.0}	52	440	280	165	124	265
CRL-4524T	23.5{ 2.4}	166{17.0}	39	510	280	165	124	305
CRL-4524F	23.5{ 2.4}	166{17.0}	52	510	280	165	124	305
CRL-5M636	35.3{ 3.6}	196{20.0}	13	630	360	127	120	370
CRL-5636W	35.3{ 3.6}	196{20.0}	26	630	360	165	120	370
CRL-5636T	35.3{ 3.6}	196{20.0}	39	630	360	165	120	370
CRL-5636F	35.3{ 3.6}	196{20.0}	52	630	360	165	120	370
CRL-5655W	53.9{ 5.5}	294{30.0}	24	630	360	165	120	370
CRL-5655T	53.9{ 5.5}	294{30.0}	36	630	360	165	120	370
CRL-6756F	54.9{ 5.6}	245{25.0}	48	750	440	220	134	435
CRL-6756V	54.9{ 5.6}	245{25.0}	60	750	440	220	134	435
CRL-6775W	73.5{ 7.5}	333{34.0}	24	750	440	220	134	435
CRL-6775T	73.5{ 7.5}	333{34.0}	36	750	440	220	134	435
CRL-6775F	73.5{ 7.5}	333{34.0}	48	750	440	220	134	435
CRL-6M7112W	109.0{11.2}	490{50.0}	24	750	440	172	134	435
CRL-7875T	73.5{ 7.5}	264{27.0}	36	870	550	220	134	500
CRL-7875F	73.5{ 7.5}	264{27.0}	48	870	550	220	134	500

NOTE: 1. Suffix -R on all model names identifies reverse winding.

2. Installation plate (base plate) for CRL-2205 ~ 3A416W is welded. If it is convenient to set it in reverse, please notify us in advance. Suffix -1 on model name identifies reverse setting.

## Slip ring capacity (Rated voltage AC600V)

Rated current	Number of poles																Model
	3	4	6	8	10	12	—	—	—	—	—	—	—	—	—	—	
30A	3	4	6	8	10	12	—	—	—	—	—	—	—	—	—	—	CRL-2205 ~3A416W
20A	3	4	6	8	10	12	14	16	18	20	22	24	26	28	30	32	
50A	3	4	6	8	10	12	—	—	—	—	—	—	—	—	—	—	CRL-4M424 ~7875F
100A	3	4	—	—	—	—	—	—	—	—	—	—	—	—	—		
150A	3	4	—	—	—	—	—	—	—	—	—	—	—	—	—	—	CRL-6756F ~7875F

## Additional L length by the number of poles

(units: mm)

Rated current	Number of poles																
	3	4	6	8	10	12	14	16	18	20	22	24	26	28	30	32	
30A	0		21	41	61	81	—	—	—	—	—	—	—	—	—	—	
20A	0			30	50	80		100	140			170	200		240		280
50A	0		30	50	80	100	—	—	—	—	—	—	—	—	—	—	
100A	30	50	—	—	—	—	—	—	—	—	—	—	—	—	—	—	
150A	97	127	—	—	—	—	—	—	—	—	—	—	—	—	—	—	

Dimensions (mm)										Mass (kg)
H	L	E	G±1	K±1	M	N	F	T	d <sub>1</sub>	
331	275	5.0	65	100	145	125	50.5	8	9	10
331	310	22.5	65	100	145	125	68.0	8	9	13
331	310	22.5	65	100	145	125	68.0	8	9	13
390	275	5.0	65	100	145	125	50.5	8	9	11
390	310	22.5	65	100	145	125	68.0	8	9	14
390	280	4.0	65	100	145	125	50.5	8	9	13
390	310	22.5	65	100	145	125	68.0	8	9	16
390	315	21.5	65	100	145	125	68.0	8	9	16
480	275	5.0	65	100	145	125	50.5	8	9	14
480	310	22.5	65	100	145	125	68.0	8	9	18
480	315	21.5	65	100	145	125	68.0	8	9	18
485	399	13.5	100	160	200	195	83.5	16	13	28
485	437	32.5	100	160	230	195	102.5	16	13	34
485	437	32.5	100	160	230	195	102.5	16	13	40
485	437	32.5	100	160	230	195	102.5	16	13	46
560	437	32.5	100	160	230	195	102.5	16	13	42
560	437	32.5	100	160	230	195	102.5	16	13	48
685	395	13.5	100	160	245	225	94.5	19	13	42
685	433	32.5	100	160	285	225	113.5	19	13	52
685	433	32.5	100	160	285	225	113.5	19	13	62
685	433	32.5	100	160	285	225	113.5	19	13	72
685	433	32.5	100	160	285	225	113.5	19	13	57
685	433	32.5	100	160	285	225	113.5	19	13	70
810	502	50.0	120	200	355	265	146.0	19	13	97
810	502	50.0	120	200	355	265	146.0	19	13	110
810	502	50.0	120	200	355	265	146.0	19	13	85
810	502	50.0	120	200	355	265	146.0	19	13	100
810	502	50.0	120	200	355	265	146.0	19	13	115
810	454	25.0	120	200	302	265	121.0	19	13	100
935	502	50.0	120	200	355	295	146.0	22	13	115
935	502	50.0	120	200	355	295	146.0	22	13	130

NOTE: For CRL-4M424 ~ 7875F, setting the installation plate (base plate) reverse is available by yourself, unless the base plate is not welded (special spec.). However, in case of reinforced bracket type (special spec.), the reverse setting is not applied. Please notify us in advance.

# CRL TYPE CABLE REEL

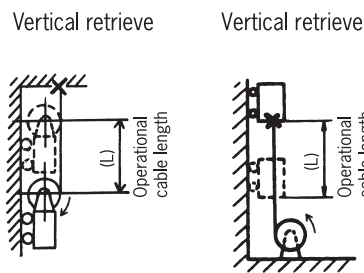
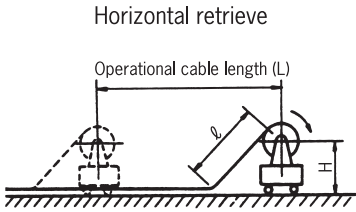

Operational cable length (L) Cable size	CRL TYPE Mobile application /Horizontal & vertical retrieve,				
	5m	10m	15m	20m	25m
2mm <sup>2</sup> ×3C 0.2kg/m ϕ 11.5	2205	2305	2A305W	3A309W	3A409W
2mm <sup>2</sup> ×4C 0.245kg/m ϕ 12.5	2205	2305	2A305W	3A309W	3A409W
3.5mm <sup>2</sup> ×3C 0.29kg/m ϕ 13	2205	2305	2A305W	3A409W	3A409W
3.5mm <sup>2</sup> ×4C 0.355kg/m ϕ 14.5	3409	3409	3A409W	3A409W	3A409W
5.5mm <sup>2</sup> ×3C 0.415kg/m ϕ 15.5	3409	3409	3A409W	3A409W	4424T
5.5mm <sup>2</sup> ×4C 0.515kg/m ϕ 17	3316	3A416W	3A416W	4424T	4524T
8mm <sup>2</sup> ×3C 0.525kg/m ϕ 17	4M424	4424W	4424W	4424T	4524T
8mm <sup>2</sup> ×4C 0.655kg/m ϕ 18.5	4M424	4424W	4424W	4524T	4524T
2mm <sup>2</sup> ×10C 0.515kg/m ϕ 19.5	4M424	4424W	4424W	4524T	4524T
14mm <sup>2</sup> ×3C 0.795kg/m ϕ 20	4M424	4424W	4524T	4524T	4524T
14mm <sup>2</sup> ×4C 1.0kg/m ϕ 22	5M636	5M636	5636W	5636W	5636T
5.5mm <sup>2</sup> ×8C 1.0kg/m ϕ 24	5M636	5M636	5636W	5636W	5636T
22mm <sup>2</sup> ×3C 1.33kg/m ϕ 27	5M636	5636W	6775W	6775W	6775T
22mm <sup>2</sup> ×4C 1.67kg/m ϕ 29	6775W	6775W	6775W	6775W	6775T
38mm <sup>2</sup> ×3C 2.02kg/m ϕ 32	6775W	6775W	6775W	6775W	6775T
38mm <sup>2</sup> ×4C 2.55kg/m ϕ 35	7875T	7875T	7875T	7875T	7875T

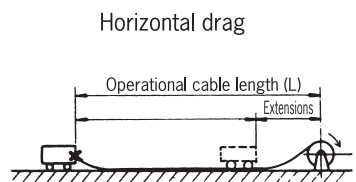

\* To protect the cable on the ground, using rollers is recommended.

Operational cable length (L) Cable size	CRL TYPE Stationary application /Horizontal retrieve				
	5m	10m	15m	20m	25m
2mm <sup>2</sup> ×3C 0.2kg/m ϕ 11.5	2205	2A205W	3A309W	3A409W	
2mm <sup>2</sup> ×4C 0.245kg/m ϕ 12.5	2205	2A205W	3A309W	3A409W	
3.5mm <sup>2</sup> ×3C 0.29kg/m ϕ 13	2205	2A205W	3A309W	3A409W	4424T
3.5mm <sup>2</sup> ×4C 0.355kg/m ϕ 14.5	3409	3409	3A409W	4424T	4424T
5.5mm <sup>2</sup> ×3C 0.415kg/m ϕ 15.5	3409	3409	3A409W	4424T	4424T
5.5mm <sup>2</sup> ×4C 0.515kg/m ϕ 17	3316	3A416W	3A416W	4424T	4524T
2mm <sup>2</sup> ×10C 0.515kg/m ϕ 19.5	4M424	4424W	4424W	4524T	4524F
8mm <sup>2</sup> ×3C 0.525kg/m ϕ 17	4M424	4424W	4424W	4524T	4524T
8mm <sup>2</sup> ×4C 0.655kg/m ϕ 18.5	4M424	4424W	4424W	4524T	5636T
14mm <sup>2</sup> ×3C 0.795kg/m ϕ 20	4M424	4424W	4524T	5636W	5655T
14mm <sup>2</sup> ×4C 1.0kg/m ϕ 22	5M636	5M636	5636W	5655T	6775T
5.5mm <sup>2</sup> ×8C 1.0kg/m ϕ 24	5M636	5M636	5636W	5655T	6775T
22mm <sup>2</sup> ×3C 1.33kg/m ϕ 27	5M636	5655W	6775W	6M7112W	6M7112W
22mm <sup>2</sup> ×4C 1.67kg/m ϕ 29	6775W	6775W	6775W	6M7112W	
38mm <sup>2</sup> ×3C 2.02kg/m ϕ 32	6775W	6775W	6M7112W		
38mm <sup>2</sup> ×4C 2.55kg/m ϕ 35	7875T				

Stationary application /Vertical retrieve							
30m	35m	40m	45m	50m	55m	60m	65m
4424F	4424F	4524F					
4424F	4524F	4524F	5636F				
4424F	4524F	4524F	5636F	5636F	6756F	6756V	6756V
4524F	4524F	4524F	5636F	5636F	6756F	6756V	6756V
4524F	4524F	4524F	5636F	5636F	6756F	6756V	6756V
4524F	4524F	5636F	5636F	5636F	6756F	6756V	6756V
4524F	5636F	5636F	5636F	6756F	6756V	6756V	6756V
5636T	5636F	5636F	6756F	6756F	6756V	6756V	
5636T	6775T	6775F	6775F	6775F	7875F	7875F	
5636T	6775T	6775F	6775F	6775F	7875F	7875F	
6775T	6775T	7875T	7875F				
6775T	6775F	7875T					
7875T							

30m	35m	40m	45m
4424F	4424F		
4424F	4524F	4524F	
4524F	4524F	5636F	6756V
5636T	6775T	6775F	6775F
5636T	6775T	6775F	
5636T	6775T	6775F	6775F
5655T	6775T		
5655T			

- NOTE: 1. Calculated at following conditions:  
 ① Cable type ..... 2PNCT  
 ② Max travel/ lift speed ..... less than 40mm/min
2. Mobile application /Horizontal, vertical retrieve  
 Stationary application /Vertical retrieve  
 ① Installation height  
 (CRL-2205 ~ 3A416W ... less than 0.5m)  
 (CRL-4M424 ~ 7875F ... less than 1.0m)
3. Stationary application /Horizontal drag  
 ① Coefficient of friction  $\mu \doteq 0.65$   
 (Between cable reel includes extensions and ground surface <flat and smooth concrete>)
4. The chart is not applicable to two-way payout. When selecting two-way payout, please take into consideration of extra reel torque.
5. Deviations due to roller guide, non-straight cable payout, concave-convex surface, low ambient temperature, etc. are not calculated. When selecting a model, please take into consideration of high mechanical stress and harsh environment conditions.
6. For high speed or high operation frequency rate, please use premium cables.
7. For any special requirements, please contact us.



# CRL TYPE CABLE REEL

Vertical lift

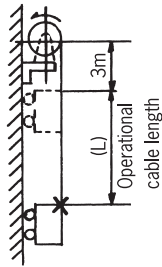

Vertical lift

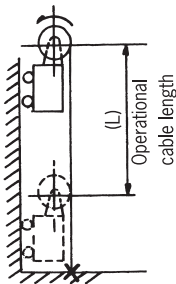

Horizontal stretch

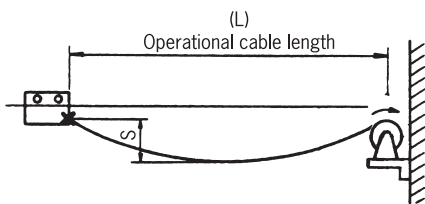
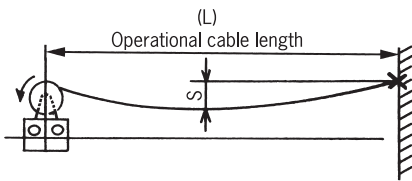

Operational cable length (L) Cable size	CRL TYPE Stationary application /Vertical lift, Mobile application			
	5m	10m	15m	20m
2mm <sup>2</sup> ×3C 0.2kg/m φ 11.5	2205	2305	3A309W	
2mm <sup>2</sup> ×4C 0.245kg/m φ 12.5	2205	2A210	3A316W	
3.5mm <sup>2</sup> ×3C 0.29kg/m φ 13	2205	2A210	3A316W	4424T
3.5mm <sup>2</sup> ×4C 0.355kg/m φ 14.5	3409	3A316W	3A416W	4424T
5.5mm <sup>2</sup> ×3C 0.415kg/m φ 15.5	3409	3A416W	4424W	4424T
5.5mm <sup>2</sup> ×4C 0.515kg/m φ 17	3316	3A416W	4424W	5655W
2mm <sup>2</sup> ×10C 0.515kg/m φ 19.5	4M424	4424W	4524T	5655W
8mm <sup>2</sup> ×3C 0.525kg/m φ 17	4M424	4424W	4424W	5655W
8mm <sup>2</sup> ×4C 0.655kg/m φ 18.5	4M424	4424W	5655W	5655W
14mm <sup>2</sup> ×3C 0.795kg/m φ 20	4M424	5636W	5655W	6M7112W
14mm <sup>2</sup> ×4C 1.0kg/m φ 22	5M636	5655W	6M7112W	6M7112W
5.5mm <sup>2</sup> ×8C 1.0kg/m φ 24	5M636	5655W	6M7112W	6M7112W
22mm <sup>2</sup> ×3C 1.33kg/m φ 27	6775W	6M7112W	6M7112W	
22mm <sup>2</sup> ×4C 1.67kg/m φ 29	6775W	6M7112W		
38mm <sup>2</sup> ×3C 2.02kg/m φ 32	6775W			

Operational cable length (L) Cable size	CRL TYPE Mobile & stationary application /Horizontal stretch		
	5m	10m	15m
2mm <sup>2</sup> ×3C 0.2kg/m φ 11.5	2205	2A210	3A316W
2mm <sup>2</sup> ×4C 0.245kg/m φ 12.5	2205	2A210	3A316W
3.5mm <sup>2</sup> ×3C 0.29kg/m φ 13	2A210	3A316W	4424W
3.5mm <sup>2</sup> ×4C 0.355kg/m φ 14.5	3316	4424W	5636W
5.5mm <sup>2</sup> ×3C 0.415kg/m φ 15.5	3316	4424W	5655W
5.5mm <sup>2</sup> ×4C 0.515kg/m φ 17	4M424	5636W	5655W
2mm <sup>2</sup> ×10C 0.515kg/m φ 19.5	4M424	5636W	5655W
8mm <sup>2</sup> ×3C 0.525kg/m φ 17	4M424	5636W	5655W
8mm <sup>2</sup> ×4C 0.655kg/m φ 18.5	4M424	5655W	6M7112W
14mm <sup>2</sup> ×3C 0.795kg/m φ 20	5M636	6775W	6M7112W
14mm <sup>2</sup> ×4C 1.0kg/m φ 22	5M636	6M7112W	
5.5mm <sup>2</sup> ×8C 1.0kg/m φ 24	5M636	6M7112W	
22mm <sup>2</sup> ×3C 1.33kg/m φ 27	6775W		
22mm <sup>2</sup> ×4C 1.67kg/m φ 29	6M7112W		
38mm <sup>2</sup> ×3C 2.02kg/m φ 32	6M7112W		



/Vertical lift	
25m	30m
4424T	4424F
5636T	5655T
5655T	5655T
5655T	6775T
5655T	6775T
5655T	6775T
6M7112W	
6M7112W	

- NOTE: 1. Calculated at following conditions:  
 ① Cable type.....2PNCT  
 ② Max travel/lift speed .....less than 40mm/min  
 2. Mobile application /Vertical lift Stationary application /Vertical lift  
 ① Extensions 3m  
 ② Mass of accessories are not included.  
 ③ Deviations due to wind load, tidal current, buoyancy, etc. are not calculated.  
 3. Mobile, stationary application /Horizontal stretch  
 ① Sag factor(S) = L×6% includes extensions  
 4. Deviations due to roller guide, non-straight cable payout, concave-convex surface, low ambient temperature, etc. are not calculated. When selecting a model, please take into consideration of high mechanical stress and harsh environment conditions.  
 5. For high speed or high operation frequency rate, please use premium cables.  
 6. For any special requirements, please contact us.

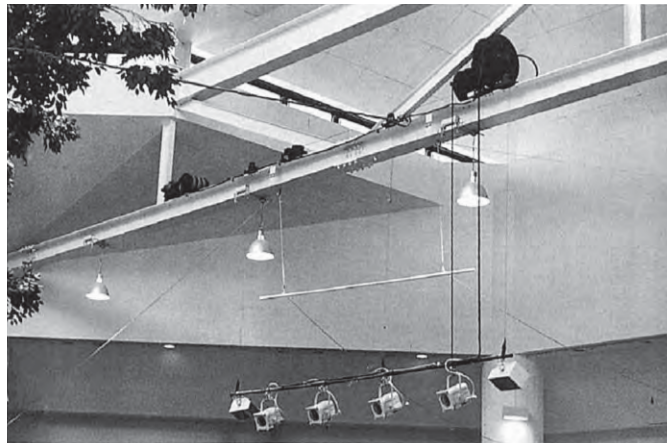

## Dimensions of Reverse setting

### ●CRL-2205-1~3A416W-1

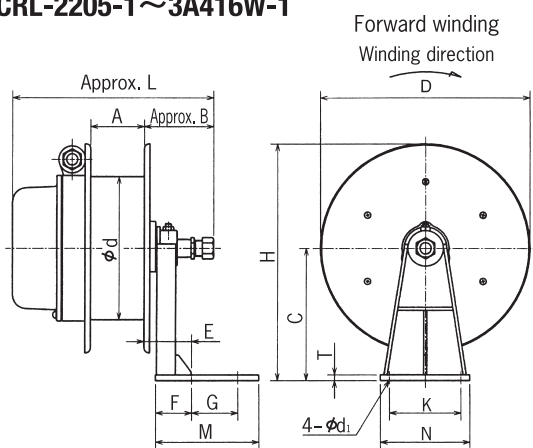

(Units: mm)

Model	Dimensions	E	F	G	M
CRL-	2205-1 • 2305-1	66.5	50.5	65	145
	2A205W-1 • 2A210-1				
	2A305W-1 • 3A09-1				
	3A309W-1 • 3A409W-1				
CRL-	3316-1 • 3A316W-1	67.5	50.5	65	145
	3A416W-1				

### ●CRL-4M424-1~7875F-1

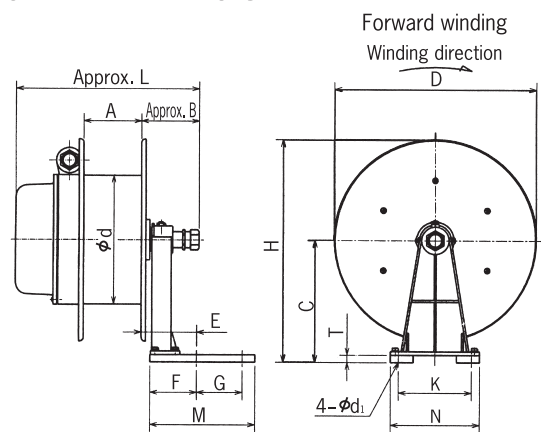

(Units: mm)

Model	Dimensions	E	F	G	M
CRL-4M424-1		86.5	83.5	100	200
CRL-4424W-1~4524F-1		105.5	102.5	100	230
CRL-5M636-1		98.5	94.5	100	245
CRL-5636W-1~5655T-1		117.5	113.5	100	285
CRL-6756F-1~6775F-1		150	146.0	120	355
CRL-7875T-1 • 7875F-1		150	146.0	120	355
CRL-6M7112W-1		125	121.0	120	302

\*Please refer to the page 9 for other models.

# CRE TYPE CABLE REEL

(Long stroke)

- Protective structure ..... Approx.IP45
- Spring replacement ..... Cartridge type

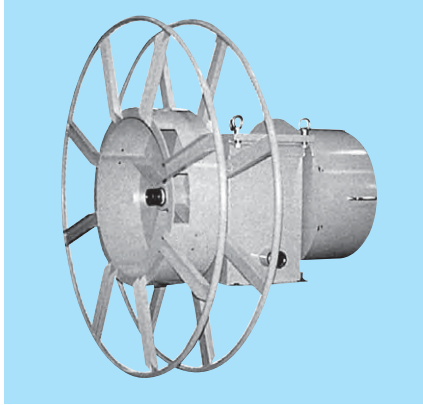

## Model description

**CRE-6M754T1A**

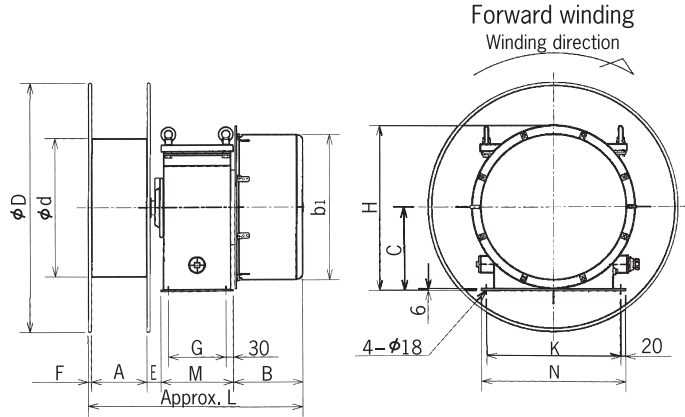
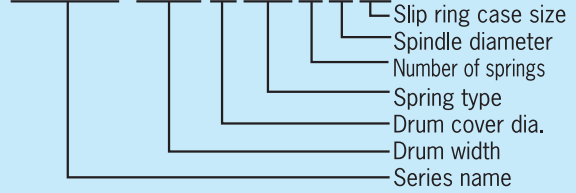

## Specifications and Dimensions

Model	Max Torque N·m(kgf·m)	Max spring tension N(kgf)	Max spring turns n	Dimensions (mm)														Mass (kg)
				D	d	A	b <sub>1</sub>	F	E	K±1	N	C	H	B	L	G±1	M	
CRE-6M754T1A	52.9{ 5.4}	239{24.4}	45	750	442	170	440	12	55	535	575	335	660	235	762	230	290	176
CRE-6M754T1B															842	310	370	183
CRE-6M754T1C															942	410	470	193
CRE-6M754F1A	52.9{ 5.4}	239{24.4}	60	750	442	170	440	12	55	535	575	335	660	295	822	230	290	196
CRE-6M754F1B															902	310	370	204
CRE-6M754F1C															1002	410	470	214
CRE-6M854F1A	52.9{ 5.4}	239{24.4}	60	870	442	170	440	12	55	535	575	335	660	295	822	230	290	201
CRE-6M854F1B															902	310	370	209
CRE-6M854F1C															1002	410	470	219
CRE-6M854V1A	52.9{ 5.4}	239{24.4}	75	870	442	170	440	12	55	535	575	335	660	355	882	230	290	222
CRE-6M854V1B															962	310	370	230
CRE-6M854V1C															1062	410	470	240
CRE-7M980W1A	78.4{ 8.0}	284{29.0}	40	1000	552	170	580	12	55	535	575	335	660	210	737	230	290	236
CRE-7M980W1B															817	310	370	243
CRE-7M980W1C															917	410	470	253
CRE-7M980T1A	78.4{ 8.0}	284{29.0}	60	1000	552	170	580	12	55	535	575	335	660	280	807	230	290	283
CRE-7M980T1B															887	310	370	290
CRE-7M980T1C															987	410	470	300
CRE-7880W1A	78.4{ 8.0}	284{29.0}	40	870	552	220	580	12	55	535	575	335	660	210	787	230	290	230
CRE-7880W1B															867	310	370	238
CRE-7880W1C															967	410	470	248
CRE-7980W1A	78.4{ 8.0}	284{29.0}	40	1000	552	220	580	12	55	535	575	335	660	210	787	230	290	237
CRE-7980W1B															867	310	370	245
CRE-7980W1C															967	410	470	255
CRE-7980T1A	78.4{ 8.0}	284{29.0}	60	1000	552	220	580	12	55	535	575	335	660	280	857	230	290	284
CRE-7980T1B															937	310	370	292
CRE-7980T1C															1037	410	470	302
CRE-71080T1A	78.4{ 8.0}	284{29.0}	60	1200	552	220	580	30	55	535	575	335	660	280	875	230	290	282
CRE-71080T1B															955	310	370	289
CRE-71080T1C															1055	410	470	299
CRE-8M10130T2B	127.0{13.0}	362{37.0}	45	1200	700	220	580	30	69	535	575	335	660	280	969	310	370	292
CRE-8M10130T2D										680	720		742					307
CRE-8M11130F2B	127.0{13.0}	362{37.0}	60	1400	700	220	580	30	69	535	575	335	660	350	1039	310	370	340
CRE-8M11130F2D										680	720		742					355
CRE-810130F2D	127.0{13.0}	362{37.0}	60	1200	700	275	580	30	69	680	720	335	742	350	1094	310	370	353
CRE-810260W2D	254.0{26.0}	725{74.0}	30	1200	700	275	580	30	69	680	720	335	742	350	1094	310	370	353
CRE-811260W2D	254.0{26.0}	725{74.0}	30	1400	700	275	580	30	69	680	720	335	742	350	1094	310	370	359

NOTE: The spindle diameter 1 is for drum width 6M~7, and the spindle diameter 2 is for drum size.

## Slip ring capacity (Rated voltage AC600V)

Rated current	Number of poles					
Slip ring case	1A	1B	1C	2B	2C	2D
20A	3~12	14~20	22~30	3~20	22~30	—
50A	3~6	8~10	12~20	3~10	12~20	—
100A	3·4	6~8	—	3~8	—	—
150A	—	3·4	—	3·4	—	—
200A	—	—	—	—	—	3·4

NOTE: 1. The ring case varies in size depending on rated current and the number of poles. Please see the suffix of the model to refer to dimensions.  
2. Number of poles not listed above could be customized upon request.

Horizontal retrieve

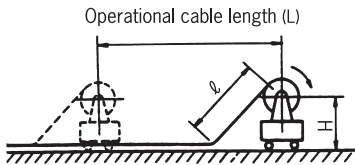

Vertical retrieve

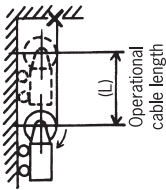

Vertical retrieve

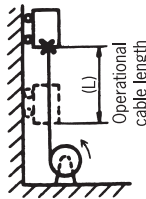

Operational cable length (L) Cable size	CRE TYPE Mobile application /Vertical & horizontal retrieve, Stationary application /Vertical retrieve				
	40m	50m	60m	70m	80m
8mm <sup>2</sup> ×3C φ 17.0 0.525kg/m	6M754T	6M754F	6M754F	6M854V	6M854V
8mm <sup>2</sup> ×4C φ 18.5 0.655kg/m	6M754T	6M754F	6M754F	6M854V	6M854V
2mm <sup>2</sup> ×10C φ 19.5 0.515kg/m	6M754T	6M754F	6M754F	6M854V	6M854V
14mm <sup>2</sup> ×3C φ 20.0 0.795kg/m	6M754T	6M754F	6M754F	6M854V	6M854V
14mm <sup>2</sup> ×4C φ 22.0 1.0kg/m	6M754T	6M854F	6M854F	6M854V	7M980T
5.5mm <sup>2</sup> ×8C φ 24.0 1.0kg/m	6M854F	6M854F	6M854F	7M980T	7980T
22mm <sup>2</sup> ×3C φ 27.0 1.33kg/m	6M854F	7M980W	7M980T	7980T	71080T
22mm <sup>2</sup> ×4C φ 29.0 1.67kg/m	7980W	7980W	7980T	71080T	71080T
38mm <sup>2</sup> ×3C φ 32.0 2.02kg/m	8M10130T	8M10130T	8M11130F	8M11130F	
38mm <sup>2</sup> ×4C φ 35.0 2.55kg/m	8M10130T	8M10130T	8M11130F	8M11130F	
60mm <sup>2</sup> ×3C φ 39.0 3.15kg/m	8M10130T	810130F			
60mm <sup>2</sup> ×4C φ 44.0 4.02kg/m	810260W				
80mm <sup>2</sup> ×3C φ 46.0 4.32kg/m	811260W				

NOTE: 1. Calculated at following conditions:

- ① Cable type 2PNCT ② Applications Mobile application /Vertical, horizontal retrieve, Stationary application /Vertical retrieve
- ③ Max travel/lift speed less than 40mm/min ④ Installation height less than 1.0m
2. Deviations due to roller guide, non-straight cable payout, low ambient temperature, etc. are not calculated. When selecting a model, please take into consideration of high mechanical stress and harsh environment conditions.
3. The chart is not applicable to two-way payout. When selecting two-way payout, please take into consideration of extra reel torque.
4. For high speed or high operation frequency rate, please use premium cables.
5. Suffix -R on all model names identifies reverse winding.
6. For any special requirements, please contact us.

## Accessories (applied to CRE TYPE)

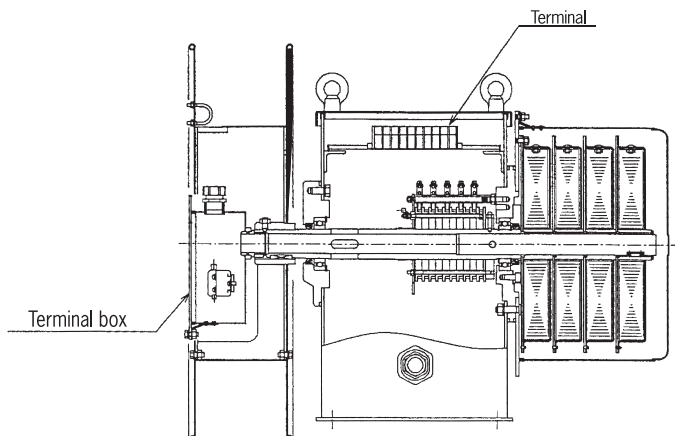

Chart of terminal box type and number of conductors

Drum width	Drum dia. (mm)	Cable size and max number of conductors						
		2mm <sup>2</sup>	5.5mm <sup>2</sup>	14mm <sup>2</sup>	22mm <sup>2</sup>	38mm <sup>2</sup>	60mm <sup>2</sup>	80mm <sup>2</sup>
6M	φ 442	14	12	6	4	—	—	—
7M.7	φ 552	22	20	12	6	4	—	—
8M.8	φ 700	30	28	20	8	4	4	4

# CRH TYPE CABLE REEL

(Center impeller type)

- Protective structure ..... Approx. IP45
- Initial spring turns system ... One-way clutch
- Spring replacement ..... Cartridge type

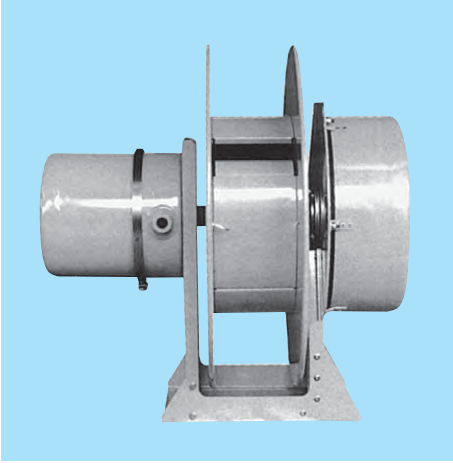

## Model description

### CRH-5675W

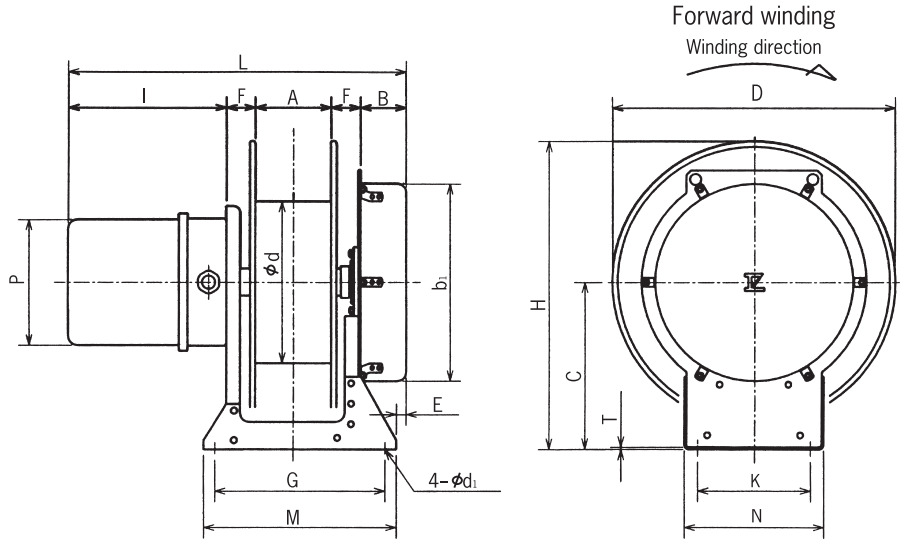
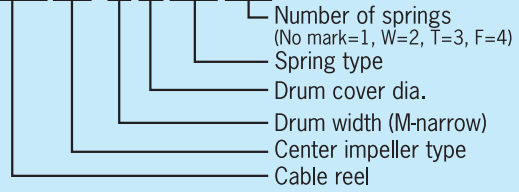

## Specifications and Dimensions

Model	Max Torque N·m(kgf·m)	Max spring tension N(kgf)	Max spring turns n	Dimensions (mm)																	Mass (kg)	
				D	d	A	I	F	B	P	L	C	H	b <sub>1</sub>	K±1	N	G±1	M	T	E		d <sub>1</sub>
CRH-5654	52.9{ 5.4}	294{30.0}	15	630	360	170	178	65	102	280	580	370	685	440	250	309	380	430	4.5	21.5	13.5	85
CRH-5654W	52.9{ 5.4}	294{30.0}	30	630	360	170	178	65	162	280	640	370	685	440	250	309	380	430	4.5	81.5	13.5	105
CRH-5654T	52.9{ 5.4}	294{30.0}	45	630	360	170	178	65	222	280	700	370	685	440	250	309	380	430	4.5	141.5	13.5	125
CRH-5654F	52.9{ 5.4}	294{30.0}	60	630	360	170	178	65	282	280	760	370	685	440	250	309	380	430	4.5	201.5	13.5	145
CRH-5675W	73.5{ 7.5}	406{41.5}	24	630	360	170	178	65	162	280	640	370	685	440	250	309	380	430	4.5	81.5	13.5	105
CRH-5675T	73.5{ 7.5}	406{41.5}	36	630	360	170	178	65	222	280	700	370	685	440	250	309	380	430	4.5	141.5	13.5	125
CRH-5675F	73.5{ 7.5}	406{41.5}	48	630	360	170	178	65	282	280	760	370	685	440	250	309	380	430	4.5	201.5	13.5	145
CRH-56108W	105.8{10.8}	588{60.0}	30	630	360	170	178	65	282	280	760	370	685	440	250	309	380	430	4.5	201.5	13.5	145
CRH-6M754	52.9{ 5.4}	240{24.5}	15	750	440	170	178	65	102	280	580	430	805	440	250	309	380	430	4.5	21.5	13.5	90
CRH-6M775	73.5{ 7.5}	333{34.0}	12	750	440	170	178	65	102	280	580	430	805	440	250	309	380	430	4.5	21.5	13.5	90
CRH-6M775W	73.5{ 7.5}	333{34.0}	24	750	440	170	178	65	162	280	640	430	805	440	250	309	380	430	4.5	81.5	13.5	110
CRH-6M7108	105.8{10.8}	480{49.0}	15	750	440	170	178	65	162	280	640	430	805	440	250	309	380	430	4.5	81.5	13.5	110
CRH-6M7108W	105.8{10.8}	480{49.0}	30	750	440	170	178	65	282	280	760	430	805	440	250	309	380	430	4.5	201.5	13.5	150
CRH-6M7150	147.0{15.0}	666{68.0}	12	750	440	170	178	65	162	280	640	430	805	440	250	309	380	430	4.5	81.5	13.5	110
CRH-6M7150W	147.0{15.0}	666{68.0}	24	750	440	170	178	65	282	280	760	430	805	440	250	309	380	430	4.5	201.5	13.5	150
CRH-78130	127.0{13.0}	460{47.0}	15	870	550	220	178	86	130	280	700	515	950	580	290	362	500	560	6	21	18.5	175
CRH-78130W	127.0{13.0}	460{47.0}	30	870	550	220	178	86	200	280	770	515	950	580	290	362	500	560	6	91	18.5	215
CRH-78130T	127.0{13.0}	460{47.0}	45	870	550	220	178	86	270	280	840	515	950	580	290	362	500	560	6	161	18.5	250
CRH-78260	254.0{26.0}	920{94.0}	15	870	550	220	178	86	200	280	770	515	950	580	290	362	500	560	6	91	18.5	215
CRH-78260W	254.0{26.0}	920{94.0}	30	870	550	220	178	86	340	280	910	515	950	580	290	362	500	560	6	231	18.5	300
CRH-8M9260	254.0{26.0}	725{74.0}	15	1000	700	220	178	86	200	280	770	580	1080	580	290	362	500	560	6	91	18.5	230
CRH-8M9260W	254.0{26.0}	725{74.0}	30	1000	700	220	178	86	340	280	910	580	1080	580	290	362	500	560	6	231	18.5	315
CRH-8M9390	382.2{39.0}	1087{111.0}	15	1000	700	220	178	86	270	280	840	580	1080	580	290	362	500	560	6	161	18.5	270



## Slip ring capacity (Rated voltage AC600V)

Rated current	Number of poles							
	3	4	6	8	10	12	16	24
20A	3	4	6	8	10	12	16	24
50A	3	4	6	8	10	12	—	—
100A	3	4	—	—	—	—	—	—
150A	3	4	—	—	—	—	—	—

150A is applicable to CRH-78130~8M9390.

## Additional L length by the number of poles (units: mm)

Rated current	Number of poles							
	3	4	6	8	10	12	16	24
20A	0		55			100	175	
50A	0		55			100	—	—
100A	55		—		—	—	—	—
150A	100		—		—	—	—	—

Vertical lift

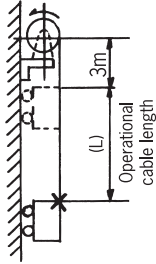

Vertical lift

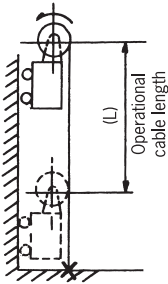

Operational cable length (L) Cable size	CRH TYPE Stationary application /Vertical lift, Mobile application /Vertical lift								
	10m	13m	15m	18m	20m	23m	25m	28m	30m
3.5mm <sup>2</sup> ×4C 0.45kg/m φ 18	5654	5654W	5654W	5654W	5654W	5654T	5654T	5654T	5654F
3.5mm <sup>2</sup> ×6C 0.62kg/m φ 21	5654	5654W	5654W	5654W	5654T	5654T	5654T	5675F	
3.5mm <sup>2</sup> ×8C 0.805kg/m φ 24	5654	5654W	5654W	5654W	5675T	5675T	5675F		
5.5mm <sup>2</sup> ×6C 0.875kg/m φ 26	6M754	6M775W	6M775W	6M775W	6M7108W	6M7108W	6M7108W		
5.5mm <sup>2</sup> ×8C 1.15kg/m φ 28	6M775	6M7108W	6M7108W	6M7108W	6M7108W	6M7150W			
8mm <sup>2</sup> ×6C 1.15kg/m φ 30	6M775	6M7108W	6M7108W	6M7108W	6M7108W	6M7150W			
5.5mm <sup>2</sup> ×10C 1.45kg/m φ 32	78130	78130W	78130W	78260W	78260W	78260W			
5.5mm <sup>2</sup> ×12C 1.67kg/m φ 35	78130	78130W	78130T	78260W	78260W	78260W			
3.5mm <sup>2</sup> ×24C 1.96kg/m φ 36	78260	78260W	78260W	78260W	78260W	78260W			
3.5mm <sup>2</sup> ×16C 1.86kg/m φ 40	8M9260	8M9260	8M9260W	8M9260W	8M9260W				

NOTE: 1. Calculated at following conditions:

- ① Cable type F-2PNCT
- ② Applications Fixed reel/Vertical lift, Moving reel/Vertical lift
- ③ Max travel/lift speed less than 40m/min
- ④ Extensions 3m

2. Mass of accessories are not included

3. Deviations due to wind load, tidal current, buoyancy, low ambient temperature, etc. are not calculated. When selecting a model, please take into consideration of harsh environment conditions.

Horizontal stretch

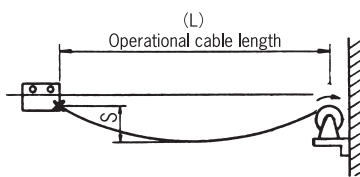
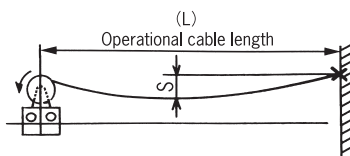

Operational cable length (L) Cable size	CRH TYPE Mobile, Stationary application /Horizontal stretch							
	10m	13m	15m	18m	20m	23m	25m	28m
3.5mm <sup>2</sup> ×4C 0.45kg/m φ 18	5654	5654W	5654W	5654T	5675T	5675T	5675T	56108W
3.5mm <sup>2</sup> ×6C 0.62kg/m φ 21	5654	5654W	5675W	5675T	56108W			
3.5mm <sup>2</sup> ×8C 0.805kg/m φ 24	5675W	5675W	56108W	56108W	6M7150W			
5.5mm <sup>2</sup> ×6C 0.875kg/m φ 26	6M775	6M7108W	6M7108W	6M7150W	6M7150W			
5.5mm <sup>2</sup> ×8C 1.15kg/m φ 28	6M7108	6M7150W	6M7150W	6M7150W				
8mm <sup>2</sup> ×6C 1.15kg/m φ 30	6M7108	6M7150W	6M7150W	6M7150W				
5.5mm <sup>2</sup> ×10C 1.45kg/m φ 32	78260	78260W	78260W					
5.5mm <sup>2</sup> ×12C 1.67kg/m φ 35	78260	78260W	78260W					
3.5mm <sup>2</sup> ×24C 1.96kg/m φ 36	78260	78260W						
3.5mm <sup>2</sup> ×16C 1.86kg/m φ 40	8M9260	8M9390						

NOTE: 1. Calculated at following conditions:

- ① Cable type F-2PNCT
- ② Application Mobile, Stationary application /Horizontal stretch
- ③ Max travel/lift speed less than 40m/min

2. Sag factor (S) = L×6% includes extensions

3. Deviations due to wind load, guide roller, low ambient temperature, etc. are not calculated. When selecting a model, please take into consideration of high mechanical stress and harsh environment conditions.



# Totally-Enclosed TORQUE MOTOR CABLE REEL

## Model description

### CR-56-TMX1001B

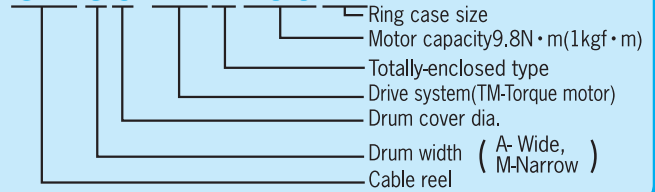

## ● Protective structure ..... Approx.IP44

### ■ Features

Applicable to install at outside without a motor cover.  
The vertical mounted motor provides less space at installation site.

### ■ Applications

Power supply for Overhead crane control  
Power supply for Receptacle boxes  
Power supply for Gondola, etc.

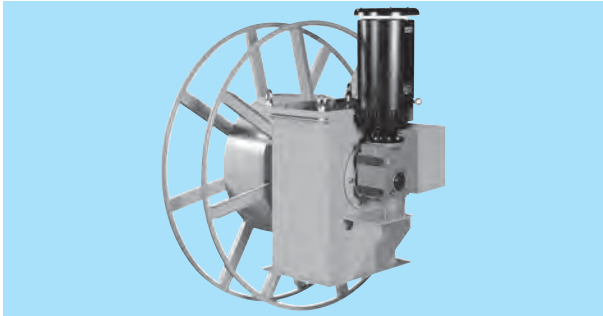

## ■ Specifications and Dimensions

Model	Gear reduction ratio	Motor torque N·m	Slip ring capacity	Voltage regulator capacity kVA				
					D	d	A	C
CR-56-TMX1001B	1/10,1/15,1/19,1/24	10{1.0}	20A~150A	2	630	360	170	335
CR-56-TMX1001C	1/10,1/15,1/19,1/24	10{1.0}	20A~50A	2	630	360	170	335
CR-67-TMX1001B	1/10,1/15,1/19,1/24	10{1.0}	20A~150A	2	750	440	220	335
CR-67-TMX1001C	1/10,1/15,1/19,1/24	10{1.0}	20A~50A	2	750	440	220	335
CR-6M8-TMX1001B	1/10,1/15,1/19,1/24	10{1.0}	20A~150A	2	870	440	170	335
CR-6M8-TMX1001C	1/10,1/15,1/19,1/24	10{1.0}	20A~50A	2	870	440	170	335
CR-79-TMX1001B	1/10,1/15,1/19,1/24	10{1.0}	20A~150A	2	1000	550	220	335
CR-79-TMX1001C	1/10,1/15,1/19,1/24	10{1.0}	20A~50A	2	1000	550	220	335
CR-7M9-TMX1001B	1/10,1/15,1/19,1/24	10{1.0}	20A~150A	2	1000	550	170	335
CR-7M9-TMX1001C	1/10,1/15,1/19,1/24	10{1.0}	20A~50A	2	1000	550	170	335
CR-7A9-TMX1001B	1/10,1/15,1/19,1/24	10{1.0}	20A~150A	2	1000	550	275	335
CR-7A9-TMX1001C	1/10,1/15,1/19,1/24	10{1.0}	20A~50A	2	1000	550	275	335
CR-8M10-TMX1002B	1/10,1/15,1/19,1/24	10{1.0}	20A~150A	2	1200	700	220	335
CR-8M10-TMX1002C	1/10,1/15,1/19,1/24	10{1.0}	20A~50A	2	1200	700	220	335
CR-810-TMX1002B	1/10,1/15,1/19,1/24	10{1.0}	20A~150A	2	1200	700	275	335
CR-810-TMX1002C	1/10,1/15,1/19,1/24	10{1.0}	20A~50A	2	1200	700	275	335
CR-811-TMX1002B	1/10,1/15,1/19,1/24	10{1.0}	20A~150A	2	1400	700	275	335
CR-811-TMX1002C	1/10,1/15,1/19,1/24	10{1.0}	20A~50A	2	1400	700	275	335
CR-812-TMX2002B	1/10,1/15,1/19	20{2.0}	20A~150A	3	1600	700	275	335
CR-812-TMX2002C	1/10,1/15,1/19	20{2.0}	20A~50A	3	1600	700	275	335
CR-812-TMX2002D	1/10,1/15,1/19	20{2.0}	200A	3	1600	700	275	335
CR-913-TMX2002B	1/10,1/15,1/19	20{2.0}	20A~150A	3	1800	900	305	335
CR-913-TMX2002C	1/10,1/15,1/19	20{2.0}	20A~50A	3	1800	900	305	335
CR-913-TMX2002D	1/10,1/15,1/19	20{2.0}	200A	3	1800	900	305	335
CR-914-TMX2002B	1/10,1/15,1/19	20{2.0}	20A~150A	3	2000	900	305	335
CR-914-TMX2002C	1/10,1/15,1/19	20{2.0}	20A~50A	3	2000	900	305	335
CR-914-TMX2002D	1/10,1/15,1/19	20{2.0}	200A	3	2000	900	305	335

NOTE: No upside down setting or side setting is allowed.

## Slip ring capacity (Rated voltage AC600V)

Rated current	Number of poles				
	1B	1C	2B	2C	2D
20A	3~20	22~30	3~20	22~30	—
50A	3~10	12~20	3~10	12~20	—
100A	3~8	—	3~8	—	—
150A	3·4	—	3·4	—	—
200A	—	—	—	—	3·4

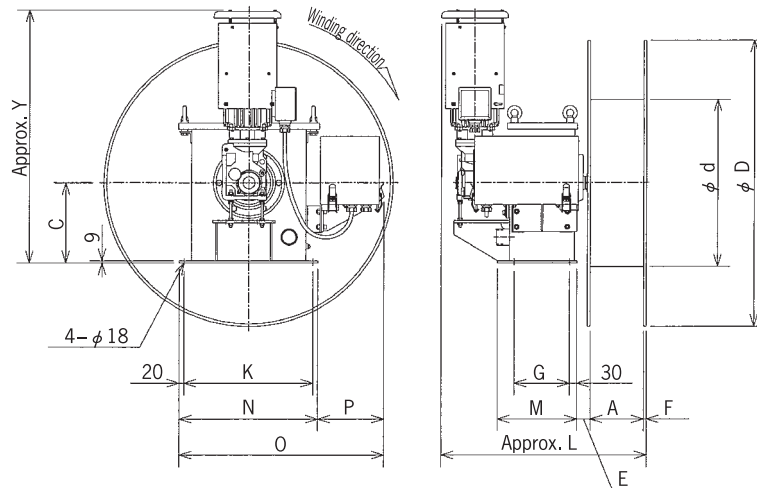

Dimensions (mm)										Mass (Kg)
E	F	O	P	K±1	N	Y	L	G±1	M	
55	5	860	285	535	575	1070	885	310	370	235
55	5	860	285	535	575	1070	985	410	470	245
55	5	860	285	535	575	1070	935	310	370	245
55	5	860	285	535	575	1070	1035	410	470	255
55	5	860	285	535	575	1070	885	310	370	255
55	5	860	285	535	575	1070	985	410	470	265
55	30	860	285	535	575	1070	935	310	370	260
55	30	860	285	535	575	1070	1035	410	470	270
55	30	860	285	535	575	1070	885	310	370	255
55	30	860	285	535	575	1070	985	410	470	265
55	30	860	285	535	575	1070	990	310	370	265
55	30	860	285	535	575	1070	1090	410	470	275
69	30	860	285	535	575	1070	970	310	370	285
69	30	860	285	535	575	1070	1070	410	470	295
69	30	860	285	535	575	1070	1025	310	370	305
69	30	860	285	535	575	1070	1125	410	470	315
69	30	860	285	535	575	1070	1025	310	370	310
69	30	860	285	535	575	1070	1125	410	470	320
69	30	930	355	535	575	1250	1025	310	370	360
69	30	930	355	535	575	1250	1125	410	470	370
69	30	1075	355	680	720	1250	1025	310	370	375
79	30	930	355	535	575	1250	1070	310	370	390
79	30	930	355	535	575	1250	1170	410	470	400
79	30	1075	355	680	720	1250	1070	310	370	405
79	30	930	355	535	575	1250	1070	310	370	395
79	30	930	355	535	575	1250	1170	410	470	405
79	30	1075	355	680	720	1250	1070	310	370	410

# TORQUE MOTOR CABLE REEL

● **Protective structure** ..... **Approx.IP33**

## ■ Features

Take advantage of torque motor for winding reels.  
Suitable for long stroke, high frequency, and high-speed winding

## ■ Applications

Power supply for Overhead crane control,  
Power supply for Receptacle boxes,  
Power supply for Gondola, Lift, etc.

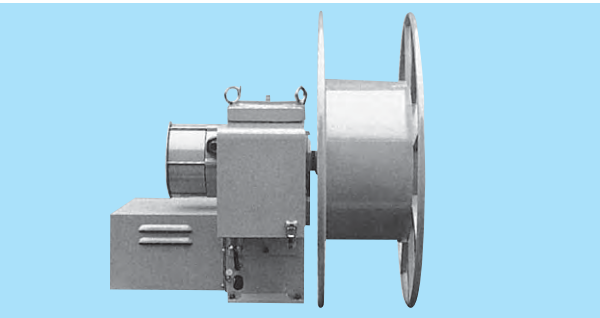

**Model description**  
**CR-89-TME400C**

- Motor capacity 39.2N·m (4kgf·m)
- Gearbox size
- Drive system (TM; Torque motor)
- Drum cover dia.
- Drum width
- Cable reel

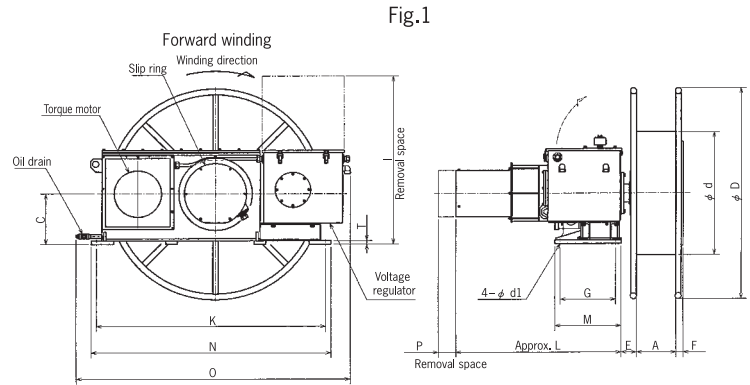

## ■ Specifications and Dimensions

Model	Gear reduction ratio	Motor torque N·m (kgf·m)	Slip ring capacity	Voltage regulator capacity kVA	Figure	Dimensions			
						D	d	A	C
CR-89-TME400C	1/16,1/20,1/25,1/32	40 {4.0}	20A~300A	6	Fig.2	1000	700	275	285
CR-810-TME400C	1/16,1/20,1/25,1/32	40 {4.0}	20A~300A	6	Fig.2	1200	700	275	285
CR-911-TME400C	1/16,1/20,1/25,1/32	40 {4.0}	20A~300A	6	Fig.2	1400	900	305	285
CR-912-TME2001	1/16,1/20,1/25,1/32	20 {2.0}	20A~300A	3	Fig.1	1600	900	305	285
CR-913-TME2001	1/16,1/20,1/25,1/32	20 {2.0}	20A~300A	3	Fig.1	1800	900	305	285
CR-914-TME2001	1/16,1/20,1/25,1/32	20 {2.0}	20A~300A	3	Fig.1	2000	900	305	285
CR-1014-TME400C	1/16,1/20,1/25,1/32	40 {4.0}	20A~300A	6	Fig.2	2000	1100	360	285

NOTE: No upside down setting or side setting is allowed.

\* Not include voltage regulator (approx. 80kg)

## Slip ring capacity (Rated voltage AC600V)

Slip ring capacity	Rated current	Number of poles											
		3	4	6	8	10	12	14	16	20	24	28	32
20	20A	3	4	6	8	10	12	14	16	20	24	28	32
50	50A	3	4	6	8	10	12	—	—	—	—	—	—
100	100A	3	4	—	—	—	—	—	—	—	—	—	—
150	150A	3	4	—	—	—	—	—	—	—	—	—	—
200	200A	3	4	—	—	—	—	—	—	—	—	—	—
300	300A	3	4	—	—	—	—	—	—	—	—	—	—

NOTE: Number of poles not listed above could be customized upon request.

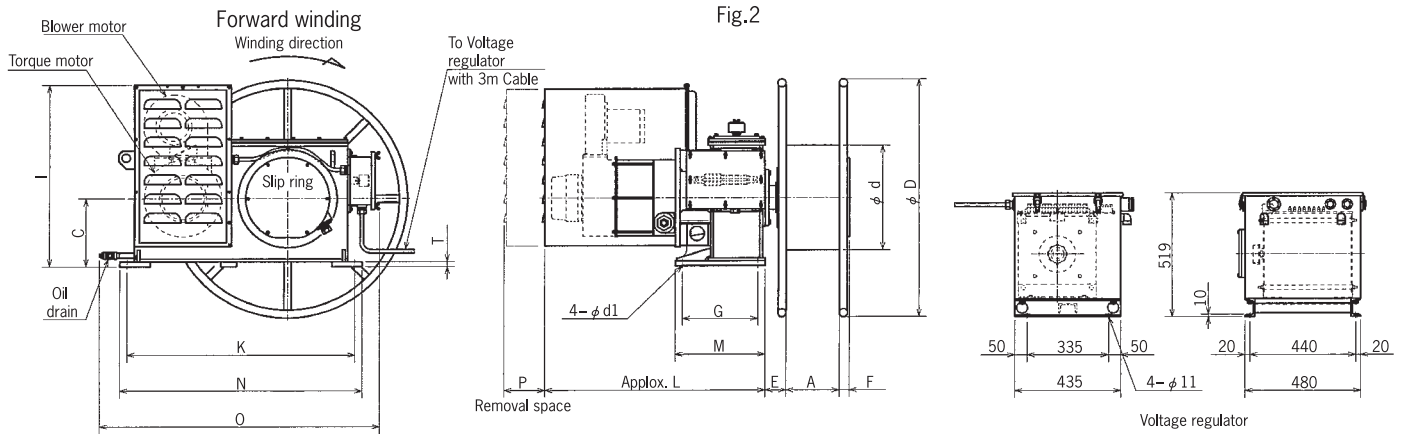

Dimensions (mm)												Mass (Kg)
E	L	F	O	P	I	G±1	K±1	M	N	T	d1	
85	920	40	1174	605	765	310	944	370	1004	20	22.0	* 580
85	920	40	1174	605	765	310	944	370	1004	20	22.0	* 590
85	920	40	1174	605	765	310	944	370	1004	20	22.0	* 610
85	800	40	1509	490	920	310	1284	370	1344	20	22.0	580
85	800	40	1509	490	920	310	1284	370	1344	20	22.0	590
85	800	40	1509	490	920	310	1284	370	1344	20	22.0	600
85	920	40	1174	605	765	310	944	370	1004	20	22.0	* 650

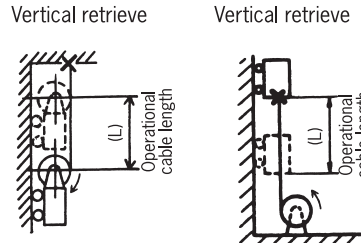
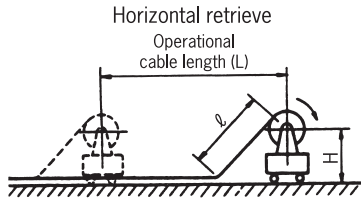

Operational cable length (L) Cable size	Torque motor type		Mobile application /Vertical & horizontal retrieve,		
	60m	70m	80m	90m	100m
14mm <sup>2</sup> ×3C 0.795kg/m φ 20	6M8-TMX100 (i=1/10)	6M8-TMX100 (i=1/10)	6M8-TMX100 (i=1/10)	6M8-TMX100 (i=1/10)	7M9-TMX100 (i=1/15)
14mm <sup>2</sup> ×4C 1.0kg/m φ 22	6M8-TMX100 (i=1/10)	6M8-TMX100 (i=1/10)	7M9-TMX100 (i=1/15)	7M9-TMX100 (i=1/15)	7M9-TMX100 (i=1/15)
5.5mm <sup>2</sup> ×8C 1.0kg/m φ 24	79-TMX100 (i=1/15)	79-TMX100 (i=1/15)	79-TMX100 (i=1/15)	79-TMX100 (i=1/15)	79-TMX100 (i=1/15)
22mm <sup>2</sup> ×3C 1.33kg/m φ 27	7A9-TMX100 (i=1/15)	7A9-TMX100 (i=1/15)	7A9-TMX100 (i=1/15)	7A9-TMX100 (i=1/15)	810-TMX100 (i=1/15)
22mm <sup>2</sup> ×4C 1.67kg/m φ 29	7A9-TMX100 (i=1/15)	7A9-TMX100 (i=1/15)	7A9-TMX100 (i=1/15)	810-TMX100 (i=1/15)	810-TMX100 (i=1/15)
38mm <sup>2</sup> ×3C 2.02kg/m φ 32	811-TMX100 (i=1/15)	811-TMX100 (i=1/15)	811-TMX100 (i=1/15)	811-TMX100 (i=1/15)	811-TMX100 (i=1/15)
38mm <sup>2</sup> ×4C 2.55kg/m φ 35	811-TMX100 (i=1/15)	811-TMX100 (i=1/15)	811-TMX100 (i=1/15)	811-TMX100 (i=1/15)	811-TMX100 (i=1/15)
60mm <sup>2</sup> ×3C 3.15kg/m φ 39	811-TMX100 (i=1/15)	811-TMX100 (i=1/15)	812-TMX200 (i=1/15)	812-TMX200 (i=1/15)	812-TMX200 (i=1/15)
60mm <sup>2</sup> ×4C 4.02kg/m φ 44	812-TMX200 (i=1/15)	812-TMX200 (i=1/15)	812-TMX200 (i=1/15)	812-TMX200 (i=1/15)	913-TMX200 (i=1/19)
100mm <sup>2</sup> ×3C 5.27kg/m φ 50	912-TME200 (i=1/20)	913-TME200 (i=1/20)	913-TME200 (i=1/20)	914-TME200 (i=1/25)	914-TME200 (i=1/25)
100mm <sup>2</sup> ×4C 6.72kg/m φ 56	912-TME200 (i=1/20)	913-TME200 (i=1/20)	913-TME200 (i=1/20)	1014-TME400 (i=1/20)	1014-TME400 (i=1/20)

NOTE: 1. Calculated at following conditions:

- ① Cable type 2PNCT ② Applications Mobile application /Vertical & horizontal retrieve, Stationary application /Vertical retrieve ③ Maximum travel/lift speed less than 40mm/min ④ Installation height less than 1.0m
2. Deviations due to roller guide, non-straight cable payout, low ambient temperature, etc. are not calculated. When selecting a model, please take into consideration of high mechanical stress and harsh environment conditions.
3. For high speed or high operation frequency rate, please use premium cables.
4. Suffix -R on all model names identifies reverse winding.
5. For any special requirements, please contact us.

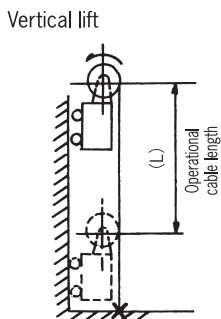
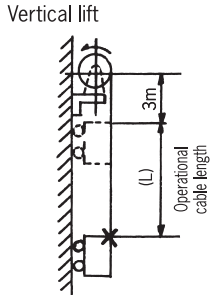

Operational cable length (L) Cable size	Torque motor type		Stationary application /Vertical lift,		
	10m	15m	20m	25m	30m
8mm <sup>2</sup> ×3C 0.525kg/m φ 17	56-TMX100 (i=1/10)	56-TMX100 (i=1/10)	56-TMX100 (i=1/10)	56-TMX100 (i=1/10)	56-TMX100 (i=1/10)
14mm <sup>2</sup> ×3C 0.795kg/m φ 20	56-TMX100 (i=1/10)	56-TMX100 (i=1/10)	56-TMX100 (i=1/15)	67-TMX100 (i=1/15)	67-TMX100 (i=1/15)
14mm <sup>2</sup> ×4C 1.0kg/m φ 22	56-TMX100 (i=1/10)	56-TMX100 (i=1/15)	67-TMX100 (i=1/15)	67-TMX100 (i=1/15)	67-TMX100 (i=1/19)
5.5mm <sup>2</sup> ×8C 1.0kg/m φ 24	56-TMX100 (i=1/10)	56-TMX100 (i=1/15)	67-TMX100 (i=1/15)	67-TMX100 (i=1/15)	67-TMX100 (i=1/19)
22mm <sup>2</sup> ×3C 1.33kg/m φ 27	67-TMX100 (i=1/15)	67-TMX100 (i=1/15)	67-TMX100 (i=1/15)	78-TMX200 (i=1/15)	78-TMX200 (i=1/15)
22mm <sup>2</sup> ×4C 1.67kg/m φ 29	67-TMX100 (i=1/15)	67-TMX100 (i=1/15)	78-TMX200 (i=1/15)	78-TMX200 (i=1/15)	78-TMX200 (i=1/19)
38mm <sup>2</sup> ×3C 2.02kg/m φ 32	78-TMX200 (i=1/15)	78-TMX200 (i=1/15)	78-TMX200 (i=1/15)	78-TMX200 (i=1/19)	89-TME400 (i=1/16)
38mm <sup>2</sup> ×4C 2.55kg/m φ 35	78-TMX200 (i=1/15)	78-TMX200 (i=1/15)	79-TMX200 (i=1/19)	89-TME400 (i=1/16)	810-TME400 (i=1/16)
60mm <sup>2</sup> ×3C 3.15kg/m φ 39	810-TMX200 (i=1/15)	810-TMX200 (i=1/24)	810-TME400 (i=1/16)	810-TME400 (i=1/20)	810-TME400 (i=1/20)
60mm <sup>2</sup> ×4C 4.02kg/m φ 44	810-TMX200 (i=1/24)	810-TME400 (i=1/16)	810-TME400 (i=1/20)	810-TME400 (i=1/25)	
100mm <sup>2</sup> ×3C 5.27kg/m φ 50	911-TME400 (i=1/16)	911-TME400 (i=1/25)	911-TME400 (i=1/32)		
100mm <sup>2</sup> ×4C 6.72kg/m φ 56	911-TME400 (i=1/25)	911-TME400 (i=1/32)			

NOTE: 1. Calculated at following conditions:

- ① Cable type 2PNCT ② Applications Stationary application /Vertical lift, Mobile application /Vertical lift ③ Maximum travel/lift speed less than 30mm/min ④ Extensions 3m
2. Mass of accessories are not included
3. Deviations due to wind load, tidal current, buoyancy, low ambient temperature, etc. are not calculated. When selecting a model, please take into consideration of harsh environment conditions.
4. Suffix -R on all model names identifies reverse winding.
5. For any special requirements, please contact us.



Stationary application /Vertical retrieve				
110m	120m	130m	140m	150m
7M9-TMX100 (i=1/15)	79-TMX100 (i=1/15)	79-TMX100 (i=1/15)	79-TMX100 (i=1/15)	7A9-TMX100 (i=1/15)
79-TMX100 (i=1/15)	79-TMX100 (i=1/15)	79-TMX100 (i=1/15)	8M10-TMX100 (i=1/15)	8M10-TMX100 (i=1/15)
8M10-TMX100 (i=1/15)	8M10-TMX100 (i=1/15)	8M10-TMX100 (i=1/15)	810-TMX100 (i=1/15)	810-TMX100 (i=1/15)
810-TMX100 (i=1/15)	811-TMX100 (i=1/15)	811-TMX100 (i=1/15)	811-TMX100 (i=1/15)	811-TMX100 (i=1/15)
810-TMX100 (i=1/15)	811-TMX100 (i=1/15)	811-TMX100 (i=1/15)	811-TMX100 (i=1/15)	811-TMX100 (i=1/15)
811-TMX100 (i=1/15)	811-TMX100 (i=1/15)	812-TMX200 (i=1/15)	812-TMX200 (i=1/15)	812-TMX200 (i=1/15)
811-TMX100 (i=1/15)	812-TMX200 (i=1/15)	812-TMX200 (i=1/15)	812-TMX200 (i=1/15)	812-TMX200 (i=1/15)
812-TMX200 (i=1/15)	812-TMX200 (i=1/15)	913-TMX200 (i=1/19)	913-TMX200 (i=1/19)	913-TMX200 (i=1/19)
913-TMX200 (i=1/19)	913-TMX200 (i=1/19)	914-TMX200 (i=1/24)	914-TMX200 (i=1/24)	914-TMX200 (i=1/24)
914-TME200 (i=1/25)	914-TME200 (i=1/25)			
1014-TME400 (i=1/20)				

### Electric circuit

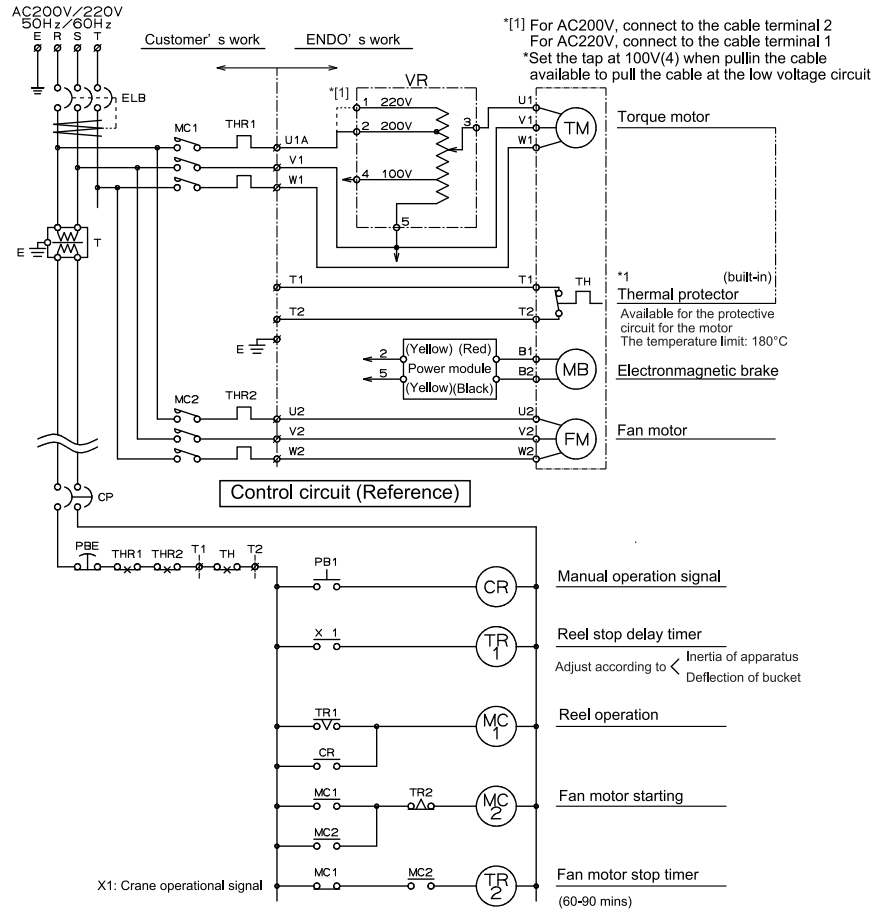

Mobile application /Vertical lift		
35m	40m	45m
56-TMX100 (i=1/15)	67-TMX100 (i=1/15)	67-TMX100 (i=1/15)
67-TMX100 (i=1/15)	67-TMX100 (i=1/19)	78-TMX200 (i=1/19)
78-TMX200 (i=1/15)	78-TMX200 (i=1/15)	78-TMX200 (i=1/15)
78-TMX200 (i=1/15)	78-TMX200 (i=1/15)	78-TMX200 (i=1/15)
78-TMX200 (i=1/15)	79-TMX200 (i=1/15)	810-TME400 (i=1/16)
89-TME400 (i=1/16)	89-TME400 (i=1/16)	810-TME400 (i=1/16)
810-TME400 (i=1/16)	810-TME400 (i=1/16)	810-TME400 (i=1/20)
810-TME400 (i=1/16)	810-TME400 (i=1/25)	810-TME400 (i=1/25)
810-TME400 (i=1/25)		

# INVERTER-DRIVEN MOTOR REEL

## ● Protective structure ... Approx.IP44 (only reel part)

### ■ Features

- Vector inverter system for the driving source provides high efficiency, energy saving and longer life of the cable.
- Applied Totally-enclosed motor for outside use and Able to use in a hostile environment.
- Optimized torque control by the vector inverter system reduces excess tension on the cable and therefore it gets cable life longer comparing the torque motor reel.
- High efficient drive by Inverter system contributes to drastic energy saving.
- On the Cable Replacement Mode, the reel is able to do forward and reverse winding by hand, and it is enable to do easy and safe cable replacement.
- Electric Control Box and Regenerative Resistor Unit are attached separately.

### ■ Applications

- For from small or middle size equipments to large size and high frequency equipments, there is a wide range of acceptable applications.

Motor capacity	1.5kW			2.2kW	
Reduction gear	Type 1	Type 2	Type 3	Type 1	Type 3
Reduction ratio	34	47.63.75	85.107.134	32.5	63.74
R(mm)	794	817	819	867	869

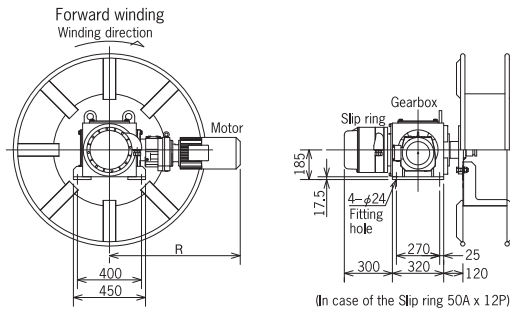

Regenerative resistor unit

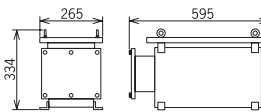

Electric control box

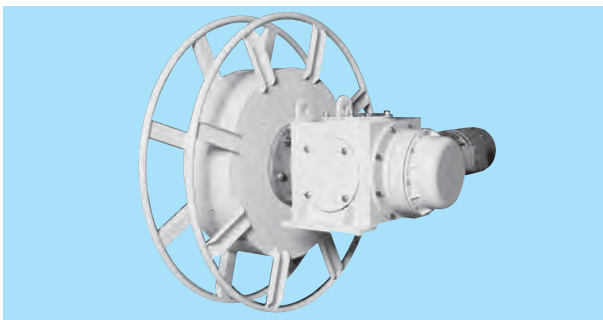
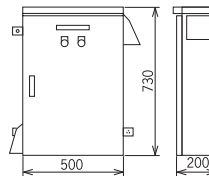

# SERVOMOTOR CABLE REEL

## ● Protective structure ... Approx.IP44

### ■ Features

- Servomotor, the sophisticated driving source, gives more efficiency, energy saving and longer cable life than the vector inverter system.
- Enable to use in a hostile environment.
- Adopted Minimum Tensional Control (\*) uniquely for the higher performance torque control structure than the vector inverter system.
- To generate the gentle winding force, it makes cable's life longer than the inverter system.
- A combination of Permanent Magnet motor and Minimum Tensional Control contributes more efficient saving energy than the inverter system.
- On the Cable Replacement Mode, the reel is able to do forward and reverse winding by hand, and it is enable to do easy and safe cable replacement.
- Embedded control system in the reel body solves the troublesome electric work.

(\*) Minimum tensional control:

The automatic calculation function that adjusts and generates the optimal and minimum winding force in response to the cable winding state.

### ■ Applications

- For from small or middle size equipments to large size and high frequency equipments, there is a wide range of acceptable applications.

Motor capacity	1.5kW	3.6kW
E(mm)	520	590

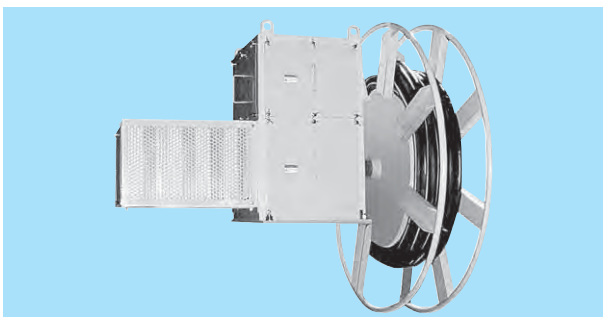
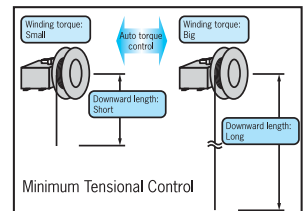
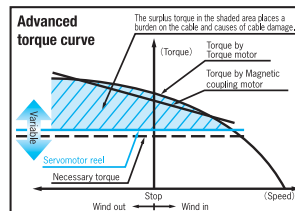
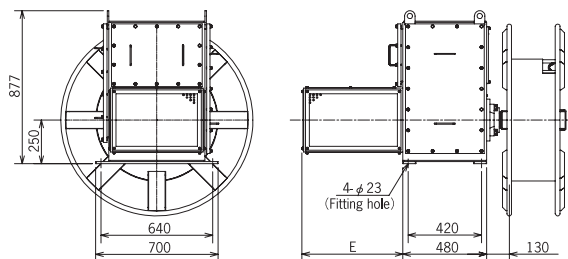

Built-in control unit



# Motor type Reel's Specifications Comparative Table

Type	Servomotor reel		Inverter-driven motor reel			Torque motor reel		
	SM15**	SM35**	VP15**	VP22**	VP30**	TMX100	TMX200	TME400C
Motor Capacity	1.5kW	3.5kW	1.5kW	2.2kW	3.0kW	9.8 N·m	19.6 N·m	39.2 N·m
Power	φ 3 200 ~230V 50/60Hz	50/60Hz	φ 3 200 ~240V 50/60Hz	50/60Hz	50/60Hz	φ 3 200/220V	50/60Hz	50/60Hz
	φ 3 380 ~480V 50/60Hz	50/60Hz	φ 3 380 ~480V 50/60Hz	50/60Hz	50/60Hz	φ 3 400/440V	50/60Hz	50/60Hz
Rating	Continuous		Continuous			Continuous		
Protective Structure	Equal to IP44		Equal to IP44 (only reel part)			Equal to IP44		Equal to IP33
Torque Control	Torque control by a servo set		Torque control by a vector inverter			Voltage controlled torque motor		
	Minimum tensional control / Stable torque control		Stable torque control					
Slip ring	20. 50. 100A		20. 50. 100. 150. 200. 300A			20. 50. 100. 150. 200. 300A		
Attachment	-		Electric control box Regenerative resistor unit			-		
Main application	Vertical retrieve (Crane etc.)		Horizontal retrieve (Moving trolley etc.)			Vertical retrieve Horizontal retrieve		
Electrical Efficiency (*)	◎ (95%cut)		◎ (90%cut)			△		
Simplified control device	○ (built-in control unit)		△ (built-in control unit)			◎		
Cable life	◎		○			△		
Quietness	◎		◎			△		
Easy torque control	◎		○			◎		
Manual winding in/out	◎		◎			△		
Against a hostile environment	○		◎			○		
High speed winding	◎		◎			○		
Low speed winding	◎		◎			◎		
Heavily loaded winding	◎		◎			○		
Maintenance span	Long		Long			Long		Short

(\*): These percentages are estimated on appropriate conditions based on TME400C as 100% and depend on the customer usage.

NOTE:1. The comparative data above is based on the general usage.

2. Servomotor reel and Inverter-driven motor reel are jointly developed products by Hitachi Plant Technologies, Ltd. and Endo Kogyo Co., Ltd.

## Reference -Excellent Energy-saving Features-

Annual electric consumption of ENDO reel with horizontal recovery at a certain factory

Motor type	Electric consumption (kWh)	Electricity cost (Yen)	CO <sub>2</sub> emission (kg)	Rate
Torque motor reel	28000	318,640	10,920	100%
Magnetic coupling motor Reel	16200	184,356	6,318	58%
Inverter-driven motor reel	3100	35,278	1,209	11%
Servomotor reel	900	10,242	351	3%

- Estimation unit: 1kWh = JPY11.38 (at July 2008)
- Estimated with 12 hours operation in a day, for 365 days a year
- CO<sub>2</sub> emission coefficient: 0.39kg-CO<sub>2</sub>/kWh

### 【Motor type】

Torque motor reel

Magnetic coupling motor Reel

Inverter-driven motor reel

Servomotor reel

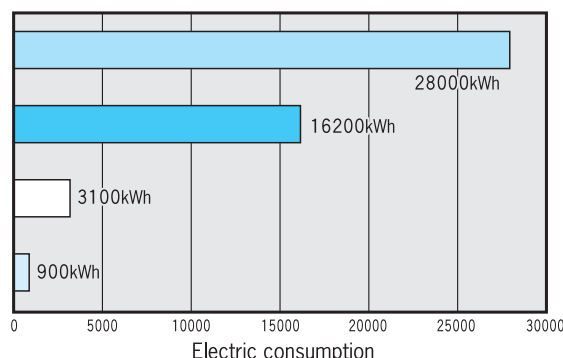

# CONTORQ TYPE CABLE REEL

## Model description

### CR-7M9-CT20BST

- └ Gearbox size(T, V)
- └ Slip unit size(S, H, M)
- └ Drive system (CT20B···Contorq 20B type)
- └ Drum cover dia.
- └ Drum width (M-Narrow)
- └ Cable reel

## ● Protective structure ..... Approx.IP55

### ■ Features

Totally-enclosed-fan-cooled motor (IP55) for winding cable reel  
Suitable for hazardous environments

### ■ Applications

Quayside crane, mixer, transfer car in a hot and dusty environment etc.

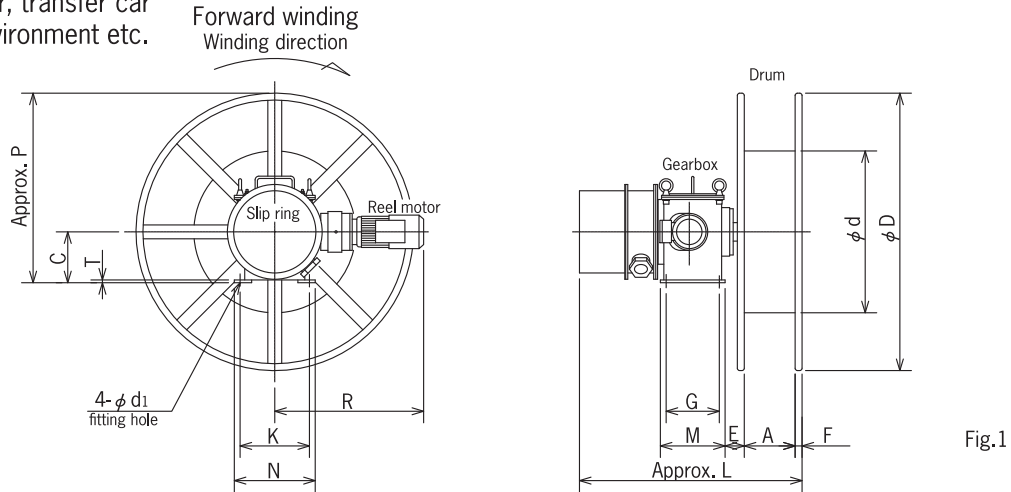

Fig.1

## ■ Specifications and Dimensions

Code	Model	Max torque N · m	Slip ring capacity	Reel motor*1 capacity kW	Figure						
						D	d	A	C	E	F
530010	CR-6M8-CT20BST	70	20~150	1.5	Fig.1	870	440	170	220	78	5
530020	CR-6M8-CT20BSV	70	20~150	1.5	Fig.2	870	440	170	220	78	5
530030	CR-6M8-CT20BHV	100	20~150	1.5	Fig.2	870	440	170	220	78	5
530040	CR-6M8-CT20BMV	130	20~150	1.5	Fig.2	870	440	170	220	78	5
530050	CR-78-CT20BMV	130	20~150	1.5	Fig.2	870	550	220	220	78	5
530060	CR-7M9-CT20BST	70	20~150	1.5	Fig.1	1000	550	170	220	83	30
530070	CR-79-CT20BST	70	20~150	1.5	Fig.1	1000	550	220	220	83	30
530080	CR-8M10-CT20BST	70	20~150	1.5	Fig.1	1200	700	220	220	83	30
530090	CR-810-CT20BST	70	20~150	1.5	Fig.1	1200	700	275	220	83	30
530100	CR-811-CT20BST	70	20~150	1.5	Fig.1	1400	700	275	220	83	30
530110	CR-811-CT20BHV	100	20~150	1.5	Fig.2	1400	700	275	220	83	30
530120	CR-812-CT20BHV	100	20~150	1.5	Fig.2	1600	700	275	220	83	30
530130	CR-812-CT20BMV	130	20~150	1.5	Fig.2	1600	700	275	220	83	30
530140	CR-913-CT20BMV	130	20~150	2.2	Fig.2	1800	900	305	220	83	30

NOTE: No upside down setting allowed.

## ■ What is Contorq type cable reel?

### ● Structure

Winding cable with Totally-enclosed-fan-cooled motor (IP55) drive.

Assembled from the following modular components:

- SLIP UNIT (slip mechanism)
- Gearbox containing reduction gear
- Slip ring
- Drum etc.

### ● Slip unit

SLIP UNIT is an equipment to maintain a torque transmission from motor.

The friction surface is composed between the friction plates radially arranged on the spindle and circular plate connected to the gears with the internal bearing (See the picture on the next page), and the friction force caused by the oil film adjusts and provides a stable torque.

## Slip ring capacity (Rated voltage AC600V)

Slip ring capacity	Rated current	Number of poles											
		3	4	6	8	10	12	14	16	20	24	28	32
20	20A	3	4	6	8	10	12	14	16	20	24	28	32
50	50A	3	4	6	8	10	12	—	—	—	—	—	—
100	100A	3	4	—	—	—	—	—	—	—	—	—	—
150	150A	3	4	—	—	—	—	—	—	—	—	—	—

NOTE: 1. In case slip ring capacity is over 20A x 20P, L length will increase.  
2. Number of poles not listed above could be customized upon request.

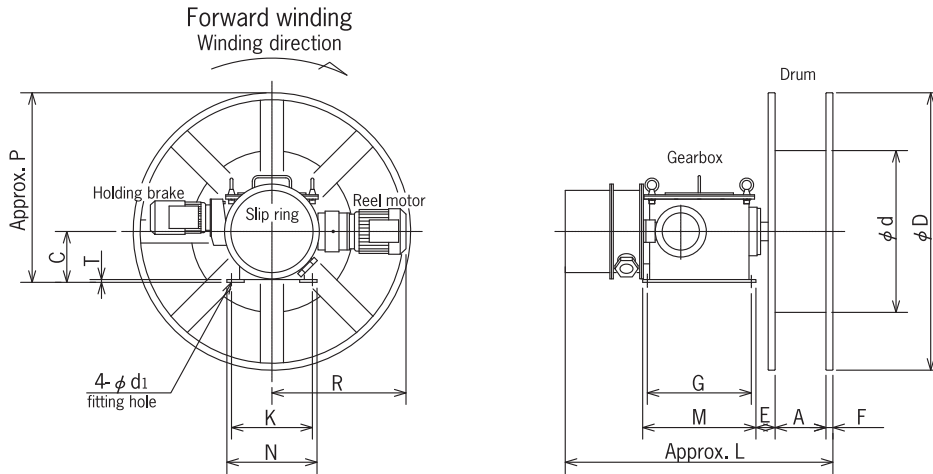
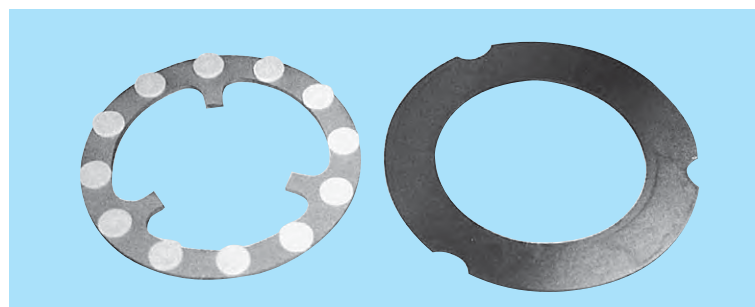
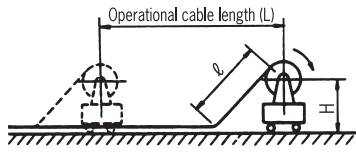

Fig.2

Dimensions (mm)										Mass (kg)
L	R	S	P	G±1	K±1	M	N	T	d1	
890	724	—	655	230	300	280	350	12	18	200
1105	724	666	655	450	350	490	390	12	18	270
1105	724	666	655	450	350	490	390	12	18	280
1105	724	666	655	450	350	490	390	12	18	280
1155	724	666	655	450	350	490	390	12	18	290
913	724	—	720	230	300	280	350	12	18	200
963	724	—	720	230	300	280	350	12	18	210
963	724	—	820	230	300	280	350	12	18	210
1018	724	—	820	230	300	280	350	12	18	220
1018	724	—	920	230	300	280	350	12	18	220
1228	724	666	920	450	350	490	390	12	18	300
1228	724	666	1020	450	350	490	390	12	18	310
1228	724	666	1020	450	350	490	390	12	18	310
1258	773	666	1120	450	350	490	390	12	18	390



Horizontal retrieve



Vertical retrieve

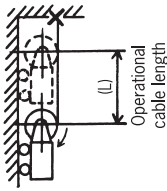

Vertical retrieve

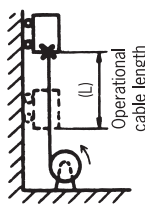

Operational cable length (L) Cable size	Contorq type Mobile application/Horizontal & vertical retrieve,				
	60m	70m	80m	90m	100m
8mm <sup>2</sup> ×3C 0.525kg/m φ 17	6M8-CT20BST	6M8-CT20BST	6M8-CT20BST	6M8-CT20BST	6M8-CT20BST
14mm <sup>2</sup> ×3C 0.795kg/m φ 20	6M8-CT20BST	6M8-CT20BST	6M8-CT20BST	6M8-CT20BST	7M9-CT20BST
14mm <sup>2</sup> ×4C 1.0kg/m φ 22	6M8-CT20BST	6M8-CT20BST	7M9-CT20BST	79-CT20BST	79-CT20BST
5.5mm <sup>2</sup> ×8C 1.0kg/m φ 24	79-CT20BST	79-CT20BST	79-CT20BST	79-CT20BST	79-CT20BST
22mm <sup>2</sup> ×3C 1.33kg/m φ 27	79-CT20BST	79-CT20BST	8M10-CT20BST	8M10-CT20BST	8M10-CT20BST
22mm <sup>2</sup> ×4C 1.67kg/m φ 29	8M10-CT20BST	8M10-CT20BST	8M10-CT20BST	810-CT20BST	810-CT20BST
38mm <sup>2</sup> ×3C 2.02kg/m φ 32	8M10-CT20BST	8M10-CT20BST	810-CT20BST	810-CT20BST	810-CT20BST
38mm <sup>2</sup> ×4C 2.55kg/m φ 35	811-CT20BHV	811-CT20BHV	811-CT20BHV	811-CT20BHV	811-CT20BHV
60mm <sup>2</sup> ×3C 3.15kg/m φ 39	811-CT20BHV	811-CT20BHV	811-CT20BHV	811-CT20BHV	812-CT20BMV

NOTE: 1. Calculated at following conditions:

- ① Cable type 2PNCT ② Applications Mobile application /Vertical & horizontal retrieve, Stationary application /Vertical retrieve
- ③ Maximum travel/lift speed less than 40mm/min ④ Installation height less than 1.0m

2. Deviations due to roller guide, non-straight cable payout, low ambient temperature, etc. are not calculated. When selecting a model, please take into consideration of high mechanical stress and harsh environment conditions.

3. For high speed or high operation frequency rate, please use premium cables.

4. Suffix -R on all model names identifies reverse winding.

5. For any special requirements, please contact us.

Vertical lift

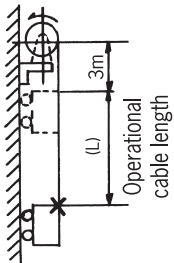

Vertical lift

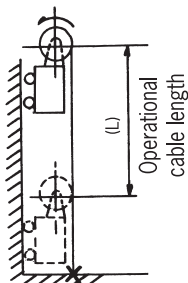

Operational cable length (L) Cable size	Contorq type Stationary application/Vertical lift, Mobile application/Vertical lift				
	10m	15m	20m	25m	30m
8mm <sup>2</sup> ×3C 0.525kg/m φ 17	6M8-CT20BSV	6M8-CT20BSV	6M8-CT20BSV	6M8-CT20BSV	6M8-CT20BHV
14mm <sup>2</sup> ×3C 0.795kg/m φ 20	6M8-CT20BSV	6M8-CT20BSV	6M8-CT20BHV	6M8-CT20BMV	6M8-CT20BMV
14mm <sup>2</sup> ×4C 1.0kg/m φ 22	6M8-CT20BSV	6M8-CT20BHV	6M8-CT20BMV	6M8-CT20BMV	
5.5mm <sup>2</sup> ×8C 1.0kg/m φ 24	6M8-CT20BSV	6M8-CT20BHV	6M8-CT20BMV	6M8-CT20BMV	
22mm <sup>2</sup> ×3C 1.33kg/m φ 27	78-CT20BMV	78-CT20BMV			
22mm <sup>2</sup> ×4C 1.67kg/m φ 29	78-CT20BMV				
38mm <sup>2</sup> ×3C 2.02kg/m φ 32	78-CT20BMV				

NOTE: 1. Calculated at following conditions:

- ① Cable type 2PNCT ② Applications Stationary application /Vertical lift, Mobile application /Vertical lift ③ Maximum travel/lift speed less than 30mm/min
- ④ Extensions 3m

2. Mass of accessories are not included

3. Deviations due to wind load, tidal current, buoyancy, low ambient temperature, etc. are not calculated. When selecting a model, please take into consideration of harsh environment conditions.

4. Suffix -R on all model names identifies reverse winding.

5. For any special requirements, please contact us.



Stationary application/Vertical retrieve				
110m	120m	130m	140m	150m
6M8-CT20BST	6M8-CT20BST			
7M9-CT20BST	79-CT20BST	79-CT20BST	79-CT20BST	
8M10-CT20BST	8M10-CT20BST	8M10-CT20BST	8M10-CT20BST	8M10-CT20BST
8M10-CT20BST	8M10-CT20BST	8M10-CT20BST	8M10-CT20BST	8M10-CT20BST
810-CT20BST	810-CT20BST	810-CT20BST	810-CT20BST	811-CT20BST
810-CT20BST	811-CT20BST	811-CT20BST	811-CT20BST	811-CT20BST
811-CT20BHV	811-CT20BHV	811-CT20BHV	811-CT20BHV	811-CT20BHV
811-CT20BHV	812-CT20BMV	812-CT20BMV	812-CT20BMV	812-CT20BMV
812-CT20BMV	812-CT20BMV	913-CT20BMV		

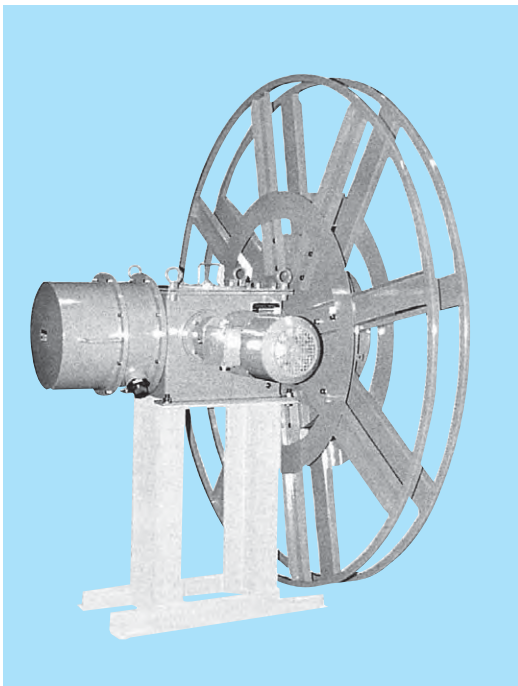

### Electric circuit (200/220/400/440V)

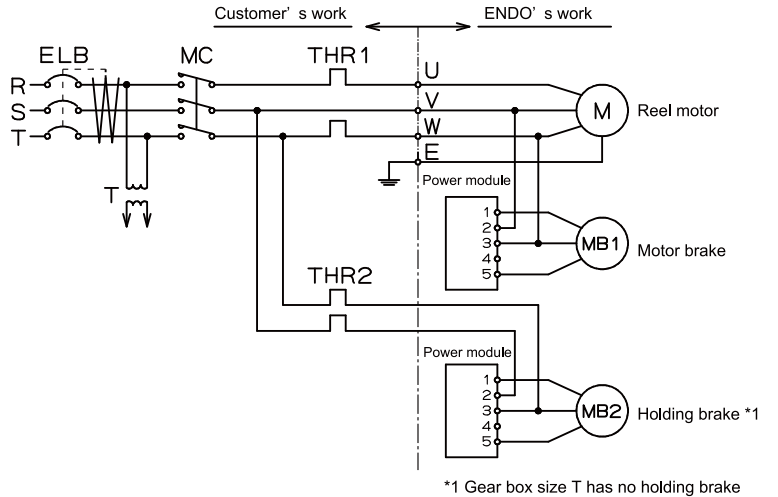

### Control circuit (Reference)

● M Rotate in winding direction at all times

AC 100/200V

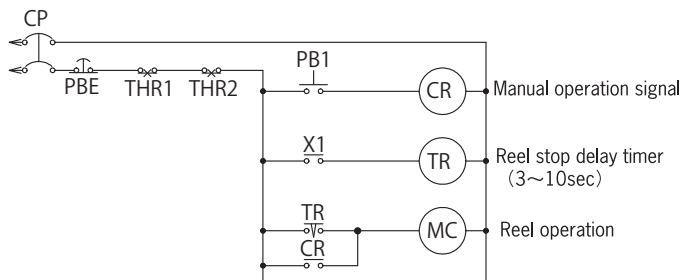

X1 : auto operation signal for reel operation  
Please Input the transfer car travel signal

● This product is manufactured and distributed under the license of METOOL Products Ltd. in Australia.

# GEARED MOTOR CABLE REEL

(Indoor use)

## Feature

Suitable for vertical winding by built-in limit switch in the geared motor

## Applications

Cranes, pendant switches, lighting fixtures etc.

## Model description

### CR-4M5-GM01106

- Overall reduction ratio
- Motor capacity (kW)
- Drive system (GM-Geared Motor)
- Drum cover dia.
- Drum width (A- Wide, M-Narrow)
- Cable reel

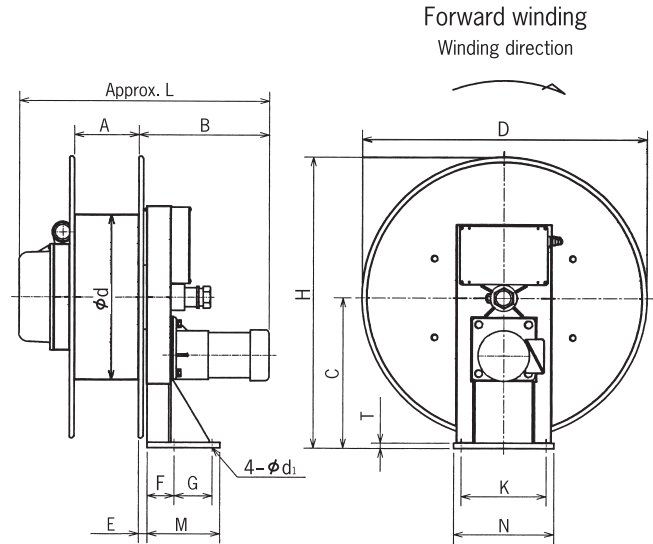
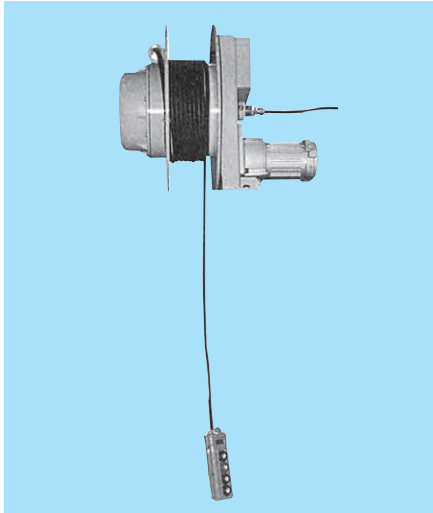

## Specification, Dimensions and Max operational cable length (Stationary application /vertical retrieve)

Model	Lifting capacity (kg) 50/60Hz	Overall reduction ratio	Geared motor		Lift speed (m/min)		Max operational cable length/ Cable outside dia.							
			Capacity kW	Voltage V	50H z	60H z	φ 15	φ 17	φ 19	φ 21	φ 23	φ 25		
CR-33-GM0145N	16/13	1/ 45	0.1	AC200/220	24~30	29~36	5	4	3					
CR-34-GM0145N	16/13	1/ 45	0.1	AC200/220	24~30	29~36	18	13	8					
CR-3A4-GM0145N	16/13	1/ 45	0.1	AC200/220	24~30	29~36		17	13					
CR-4M5-GM01106	32/27	1/106	0.1	AC200/220	13~16	15~19		17	18	14				
CR-4M6-GM01106	32/27	1/106	0.1	AC200/220	13~16	15~19		17	18	19				
CR-5M6-GM01106	25/21	1/106	0.1	AC200/220	16~20	19~24		21	22	18	18	14		
CR-6M7-GM01212	41/34	1/212	0.1	AC200/220	10~13	12~15						22	22	

- NOTE:
- 1.Max operational cable length includes extensions. If there are some accessories, please take into consideration of the mass.
  - 2.Deviations due to roller guide, wind load, low ambient temperature, etc. are not calculated. When selecting a model, please take into consideration of high mechanical stress and harsh environment conditions.
  - 3.For outdoor use, please attach a cover.
  - 4.Electric control unit of cable reel is not included.
  - 5.Suffix -R on all model names identifies reverse winding.
  - 6.For any special requirements, please contact us.

Vertical lift (Standard)

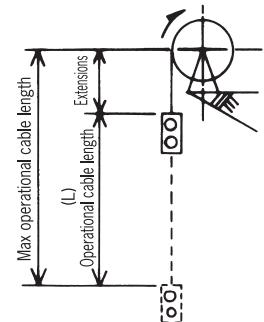

## Slip ring capacity (Rated voltage AC600V)

Rated current	Number of poles												Model
	3	4	6	8	10	12	—	—	—	—	—	—	
30A	3	4	6	8	10	12	—	—	—	—	—	—	CR-33-GM0145N~3A4-GM0145N
20A	3	4	6	8	10	12	14	16	20	24	28	32	CR-4M5-GM01106~6M7-GM01212
50A	3	4	6	8	10	12	—	—	—	—	—	—	
100A	3	4	—	—	—	—	—	—	—	—	—	—	CR-6M7-GM01212
150A	3	4	—	—	—	—	—	—	—	—	—	—	

NOTE: Number of poles not listed above could be customized upon request.

## Additional L length by the number of poles

(units: mm)

Rated current	Number of poles											
	3	4	6	8	10	12	14	16	20	24	28	32
30A	0		21	41	61	81	—	—	—	—	—	—
20A	0			30	50	80	100	140	200	240	280	
50A	0		30	50	80	100	—	—	—	—	—	—
100A	30	50	—	—	—	—	—	—	—	—	—	—
150A	97	127	—	—	—	—	—	—	—	—	—	—

φ 28	φ 31	Dimensions (mm)														Mass (kg)	
		D	d	A	B	C	H	L	E	G±1	K±1	M	F	N	T		d1
		350	230	75	300	222	397	485	19	60	160	150	70	210	10	11	38
		440	230	75	300	222	442	485	19	60	160	150	70	210	10	11	39
		440	230	110	300	222	442	520	19	60	160	150	70	210	10	11	40
		510	280	127	320	275	530	595	19	60	210	150	70	260	10	11	46
		630	280	127	320	335	650	595	19	60	210	150	70	260	10	11	47
		630	360	127	320	335	650	595	19	60	210	150	70	260	10	11	50
20	16	750	440	170	335	350	725	653	25	60	210	160	80	260	10	13	73

## Upper and lower stop limit switch mechanism

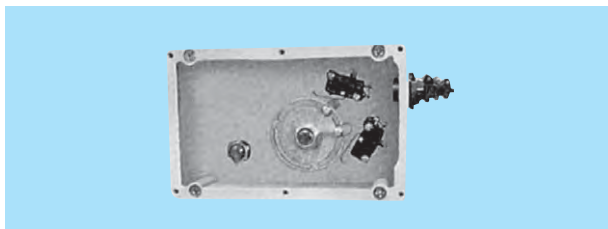

Model	Frequency of drum detection
CR-33-GM0145N~3A4-GM0145N	Up to 20 turns
CR-4M5-GM01106~5M6-GM01106	Up to 18 turns
CR-6M7-GM01212	Up to 15 turns

## Electric circuit (Reference)

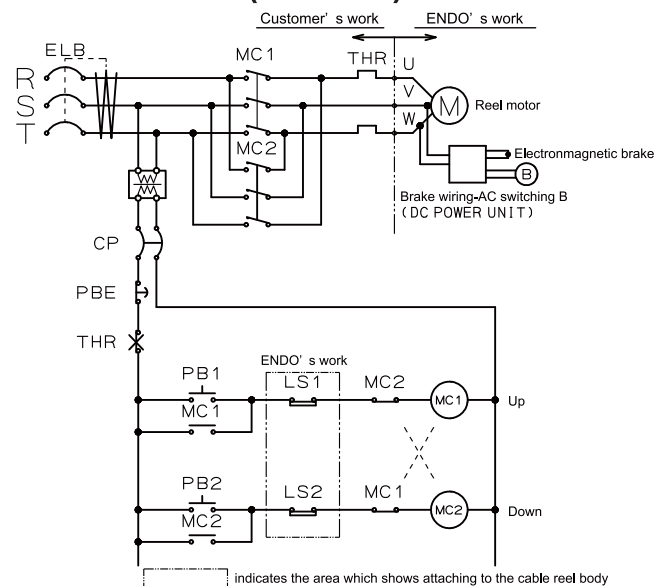

# HYDRAULIC MOTOR CABLE REEL

● Protective structure ..... Approx.IP54

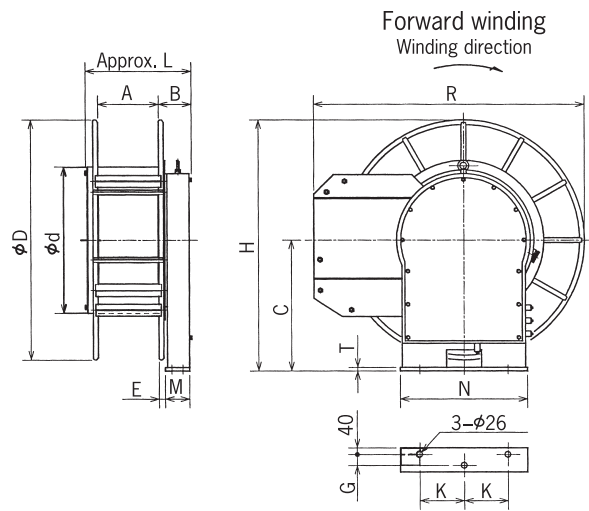

## Model description

### CRD-8A9L-OM10

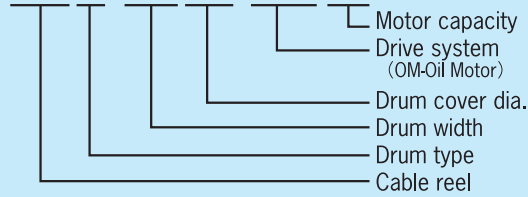

## Dimensions (Rated voltage AC600)

Model	Dimensions (mm)															Mass (kg)
	D	d	A	B	C	H	L	R	E	G	K	M	N	T		
CRD-8A9L-OM10 150A×4P	1100	670	306	130	620	1170	535	1230	37	50	200	120	580	16	270	
CRD-8A10L-OM12 150A×4P	1250	670	306	130	650	1275	535	1380	37	50	200	120	580	16	280	
CRD-8LA11L-OM20 200A×4P	1500	750	306	170	780	1530	662	1615	39	140	220	210	630	16	310	

NOTE:1.No upside down setting is allowed.  
2.For any special requirements, please contact us.

## Max operational cable length (Mobile application/Horizontal retrieve)

(units: mm)

Model	Type	3PNCT		2PNCT		3PNCT		3PNCT		2PNCT		3PNCT		3PNCT	
		Size	Weight	Outside dia.	Size	Weight	Outside dia.	Size	Weight	Outside dia.	Size	Weight	Outside dia.	Size	Weight
CRD-8A9L-OM10 150A×4P	100	100	80												
CRD-8A10L-OM12 150A×4P	130	130	110												
CRD-8LA11L-OM20 200A×4P							120	100	90	60					

## Conditions

- Operating the hydraulic motor to forward and reverse make the cable wind and payout.
- When manual operation, please take into consideration of bypass circuit for hydraulic circuit.
- And brake type needs to release the brake to payout cable.

Without brake type

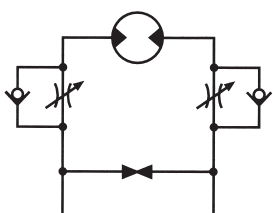

With brake type

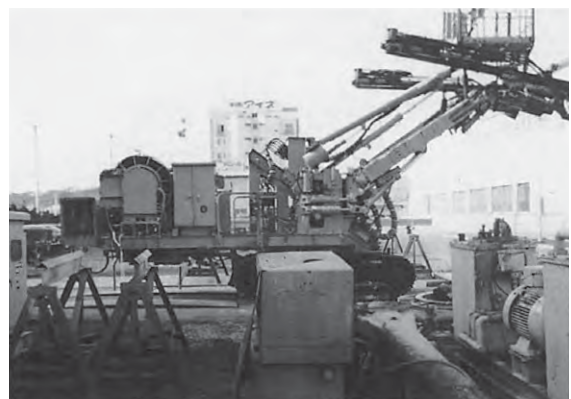
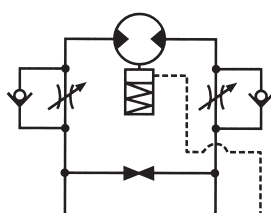

- Cable reel without brake requires the cable fall-prevention construction
- Motor brake applies external pilot systems. (Braking release pressure is over 1MPa.)

# WHR TYPE HOSE REEL

(Low pressure double winding)

- **Maximum Working pressure**  
 ...less than 1.5MPa{15kgf/cm<sup>2</sup>}  
 ※Not available for oxygen or acetylene.

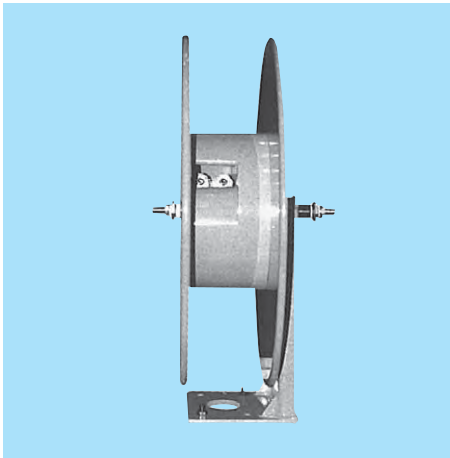

## Model description

### WHR-3A516W

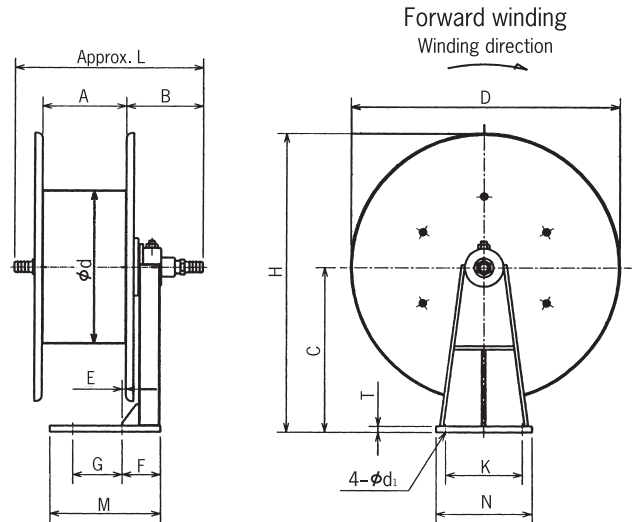
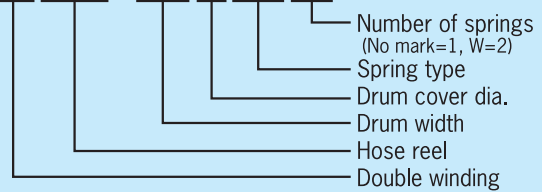

## Specifications and Dimensions

Model	Max Torque N·m(kgf·m)	Max spring tension N(kgf)	Max spring turns n	Connection size Rc	Dimensions (mm)															Mass (kg)
					D	d	A	B	C	H	L	E	G±1	K±1	M	N	F	T	d1	
WHR-2A305	4.9(0.5)	49( 5.0)	20	3/8	350	200	110	102	215	390	249	22.5	65	100	145	125	68.0	8	9	10
WHR-3A409	8.8(0.9)	73( 7.5)	19	3/8	440	230	110	102	260	480	249	22.5	65	100	145	125	68.0	8	9	12
WHR-3A516	15.6(1.6)	132(13.5)	13	1/2	510	230	110	106	300	555	267	22.5	65	100	160	150	73.5	8	9	17
WHR-3A516W	15.6(1.6)	132(13.5)	26	1/2	510	230	110	106	300	555	303	22.5	65	100	160	150	73.5	8	9	20

NOTE: Only forward winding is available.

## Max operational cable length (Mobile application/Horizontal & vertical retrieve, Stationary application/Vertical retrieve)

Model	Outside dia.	Operational cable length (L) (m)			
		φ 14	φ 17	φ 20	φ 23
WHR-2A305		9	6	4	
WHR-3A409		15	11	7	
WHR-3A516			11	11	9
WHR-3A516W		20	16	11	

NOTE: 1. Calculated at following conditions:

- ① Fluid..... Air
  - ② Working pressure..... 1.0MPa (10kgf/cm<sup>2</sup>)
  - ③ Application..... Mobile application/Horizontal & vertical retrieve, Stationary application/Vertical retrieve
  - ④ Maximum travel/lift ... less than 30mm/min
2. Deviations due to roller guides, non-straight cable payout, low ambient temperature, etc. are not calculated. When selecting a model, please take into consideration of high mechanical stress and harsh environment conditions.

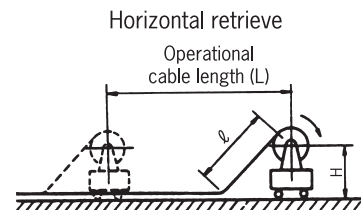

Vertical retrieve      Vertical retrieve

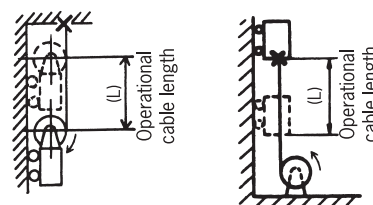

# HR TYPE HOSE REEL

## (Standard)

- **Maximum Working pressure** ..... less than 1.5MPa{15kgf/cm<sup>2</sup>}
- **Fluid** ... Air, nitrogen, argon, carbon dioxide, general hydraulic oil, grease, industrial water

※Please contact us if the hose reel has different application from above fluids.

### ●HR-2205~3A516W

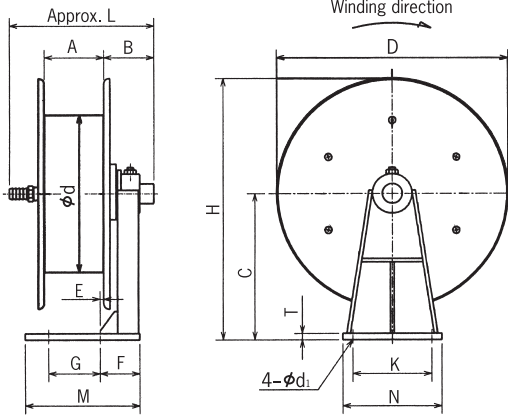

### ●HR-4524~6975T

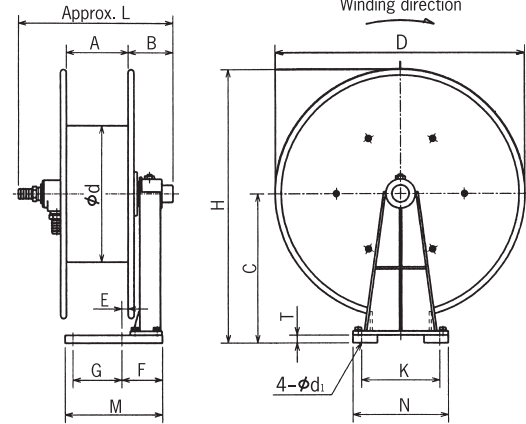

## Specifications and Dimensions

Model	Max Torque N·m(kgf·m)	Max spring tension N(kgf)	Max spring turns n	Connection size Rc	Dimensions (mm)															Mass (kg)
					D	d	A	B	C	H	L	E	G±1	K±1	M	N	F	T	d <sub>1</sub>	
HR-2205	4.9 (0.5)	49(5.0)	20	3/8	292	200	75	64	185	331	185	5.0	65	100	145	125	50.5	8	9	8
HR-2305	4.9 (0.5)	49( 5.0)	20	3/8	350	200	75	64	215	390	185	5.0	65	100	145	125	50.5	8	9	9
HR-2A305W	4.9 (0.5)	49( 5.0)	39	3/8	350	200	110	64	215	390	220	22.5	65	100	145	125	68.0	8	9	11
HR-3416	15.6(1.6)	132(13.5)	13	1/2	440	230	75	65	260	480	195	4.0	65	100	145	125	50.5	8	9	12
HR-3A409W	8.8 (0.9)	73( 7.5)	38	1/2	440	230	110	65	260	480	230	22.5	65	100	145	125	68.0	8	9	16
HR-3A416W	15.6(1.6)	132(13.5)	26	1/2	440	230	110	65	260	480	230	21.5	65	100	145	125	68.0	8	9	16
HR-3A516W	15.6(1.6)	132(13.5)	26	1/2	510	230	110	65	300	555	230	21.5	65	100	160	150	73.5	8	9	20
HR-4524	23.5(2.4)	166(17.0)	13	3/4	510	280	127	90	305	560	320	13.5	100	160	200	195	83.5	16	13	27
HR-4524W	23.5(2.4)	166(17.0)	26	3/4	510	280	127	90	305	560	320	13.5	100	160	200	195	83.5	16	13	32
HR-4524T	23.5(2.4)	166(17.0)	39	3/4	510	280	127	90	305	560	320	13.5	100	160	200	195	83.5	16	13	38
HR-4624W	23.5(2.4)	166(17.0)	26	3/4	630	280	127	90	370	685	320	13.5	100	160	228	200	83.5	16	13	36
HR-4624T	23.5(2.4)	166(17.0)	39	3/4	630	280	127	90	370	685	320	13.5	100	160	228	200	83.5	16	13	41
HR-5736	35.3(3.6)	196(20.0)	13	1	750	360	127	82	435	810	330	13.5	100	160	245	245	94.5	19	13	46
HR-5736W	35.3(3.6)	196(20.0)	26	1	750	360	127	82	435	810	330	13.5	100	160	245	245	94.5	19	13	53
HR-5736T	35.3(3.6)	196(20.0)	39	1	750	360	127	82	435	810	330	13.5	100	160	245	245	94.5	19	13	60
HR-6855	53.9(5.5)	245(25.0)	12	1 1/4	870	440	166	82	500	935	390	23.0	120	200	286	295	104.0	22	13	66
HR-6855W	53.9(5.5)	245(25.0)	24	1 1/4	870	440	166	82	500	935	390	23.0	120	200	286	295	104.0	22	13	77
HR-6855T	53.9(5.5)	245(25.0)	36	1 1/4	870	440	166	82	500	935	390	23.0	120	200	286	295	104.0	22	13	88
HR-6975W	73.5(7.5)	333(34.0)	24	1 1/4	1000	440	166	97	565	1065	390	23.0	120	200	301	335	119.0	22	13	102
HR-6975T	73.5(7.5)	333(34.0)	36	1 1/4	1000	440	166	97	565	1065	390	23.0	120	200	301	335	119.0	22	13	117

- NOTE: 1.Suffix -R on all model names identifies reverse winding.  
 2.Installation plate (base plate) for HR-2205~3A516W is welded. If you prefer to set it reverse, please notify us in advance. Suffix -1 on model name identifies reverse setting.  
 3.For HR-4524~6975T, setting the installation plate (base plate) reverse is available by yourself, unless the base plate is not welded (special spec.). However, in case of reinforced bracket type (special spec.), the reverse setting is not applied.  
 4.For any special fluids, please contact us.  
 5.For any special requirements, please contact us.



### Model description

## HR-4524W

- Number of springs  
(No mark=1, W=2, T=3)
- Spring type
- Drum cover dia.
- Drum width (A-wide)
- Hose reel

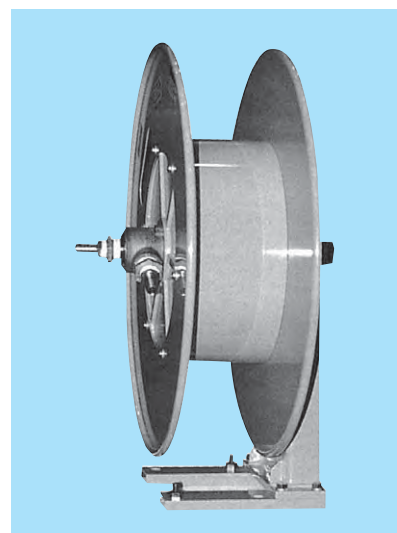

Horizontal retrieve

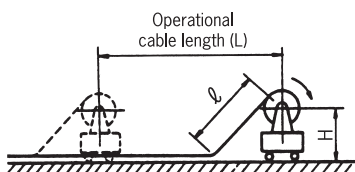

Vertical retrieve

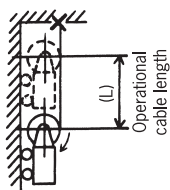

Vertical retrieve

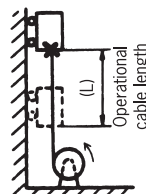

Operational cable length (L) Hose size	HR Type	Mobile application/Horizontal & vertical retrieve, Stationary application/Vertical retrieve						
		5m	10m	15m	20m	25m	30m	35m
$\phi 6.3 \times \phi 13.8$	2205	2305	2A305W	2A305W	3A409W			
$\phi 6.3 \times \phi 14.5$	2205	2305	2A305W	2A305W	3A409W			
$\phi 9.5 \times \phi 17$	2305	2A305W	3A409W	3A409W	4524T	4624T		
$\phi 9.5 \times \phi 18$	2305	2A305W	3A409W	3A409W	4524T	4624T		
$\phi 12.7 \times \phi 20.5$	3416	3A416W	3A516W	4524W	4624T	4624T	5736T	
$\phi 12.7 \times \phi 22.5$	3416	3A416W	3A516W	4524W	4624T	4624T	5736T	
$\phi 15.9 \times \phi 25$	4524	4524W	4624W	4624W	5736W	5736T	6855T	
$\phi 15.9 \times \phi 26$	4524	4524W	4624W	4624W	5736W	5736T	6855T	
$\phi 19 \times \phi 27.5$	4524	4624W	4624W	5736W	5736T	5736T	6855T	
$\phi 19 \times \phi 30$	5736	5736	5736W	5736W	5736T	6855W	6855T	
$\phi 25.4 \times \phi 34$	5736	5736	5736W	6855W	6855W	6855T	6975T	
$\phi 25.4 \times \phi 37.5$	6855	6855	6855W	6855W	6855T	6975W	6975T	
$\phi 31.8 \times \phi 44$	6855	6855	6855W	6975W	6975W			
$\phi 31.8 \times \phi 47$	6855	6855	6855W	6975W				

NOTE: 1. Calculated at following conditions:

- ① Fluid..... Air
- ② Working pressure..... 1.0MPa {10kgf/cm<sup>2</sup>}
- ③ Application..... Mobile application/Horizontal & vertical retrieve, Stationary application/Vertical retrieve
- ④ Maximum travel/lift... less than 30mm/min
- ⑤ Installation height ...  $\left( \begin{array}{l} \text{HR-2205} \sim \text{3A516W} \cdots \text{less than 0.5m} \\ \text{HR-4524} \sim \text{6975T} \cdots \text{less than 1.0m} \end{array} \right)$

2. Deviations due to roller guides, non-straight cable payout, low ambient temperature, etc. are not calculated. When selecting a model, please take into consideration of high mechanical stress and harsh environment conditions.

# WORRY TYPE HOSE REEL

(High pressure double winding)

- Maximum Working pressure  
 ...less than 21.0MPa{210kgf/cm<sup>2</sup>}

## Model description

### WORRY-4S655-J

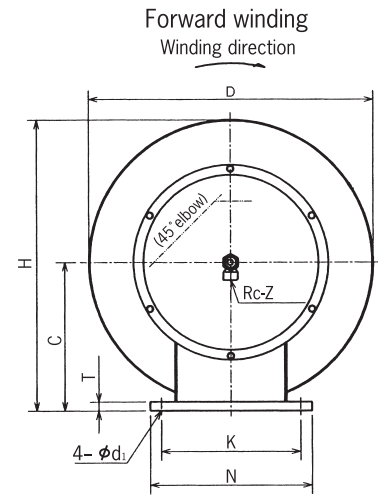
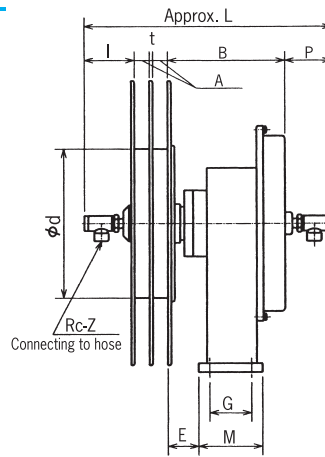
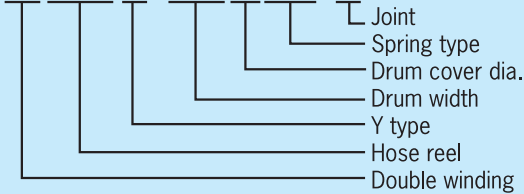

## Specifications and Dimensions

Model	Max Torque N·m{kgf·m}	Max spring tension N{kgf}	Max spring turns n	Hose inlet 2-Z Rc	Dimensions (mm)																	Mass (kg)
					D	d	A	B	C	H	I	E	G±1	K±1	M	N	P	L	T	t	d1	
WORRY-3S424-J	23.5{2.4}	196{20}	13	1/4	440	230	17x2	162	265	485	70	30	60	160	90	195	70	346	12	10	13	34
WORRY-3S524-J	23.5{2.4}	196{20}	13	1/4	510	230	17x2	162	265	520	70	30	60	160	90	195	70	346	12	10	13	38
WORRY-4S536-J	35.3{3.6}	245{25}	13	3/8	510	280	25x2	186	265	520	80	30	75	250	115	290	80	398	12	2	18	55
WORRY-4S654-J	52.9{5.4}	382{39}	15	3/8	630	280	22x2	206	350	665	85	30	85	300	125	340	80	417	12	2	18	75
WORRY-4S655-J	53.9{5.5}	382{39}	12	1/2	630	280	26x2	198	265	580	90	30	75	250	115	290	90	439	12	9	18	75
WORRY-5S775-J	73.5{7.5}	402{41}	12	1/2	750	360	25x2	206	350	725	100	30	85	300	125	340	90	453	12	2	18	90
WORRY-6S8150-J	147.0{15.0}	666{68}	12	3/4	870	440	82	283	350	785	110	30	85	300	125	340	110	585	12	—	18	110

- NOTE: 1. Suffix -R on all model names identifies reverse winding.  
 2. 45 angles elbow (equal to YOKOHAMA HYDEX #1035) for hose connection is attached to the cable reel.  
 3. High resistance to pressurization and high flexibility is recommended for a hose.  
 4. When using a long cable, please select a twin hose with W/B.  
 5. For any special fluids, please contact us.  
 6. For any special requirements, please contact us.

※WHRY models also would be offered if the maximum working pressure is be less than 1.5MPa{15kgf/cm<sup>2</sup>} for general purpose mineral hydraulic oils. WHRY models change joint parts from WORRY models.

Forth winding

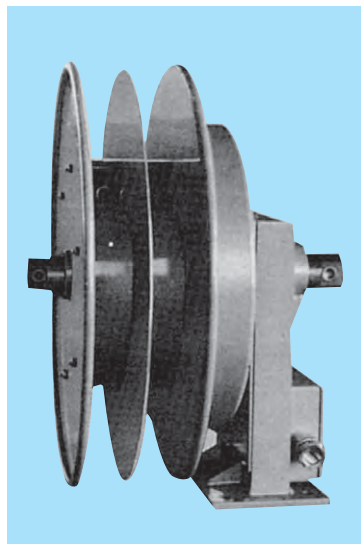

Double winding

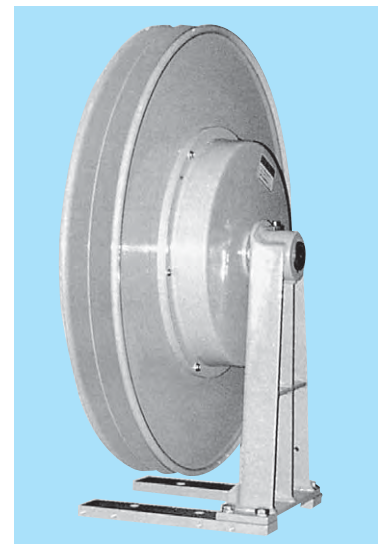

Forth and double winding listed above are customized upon request.

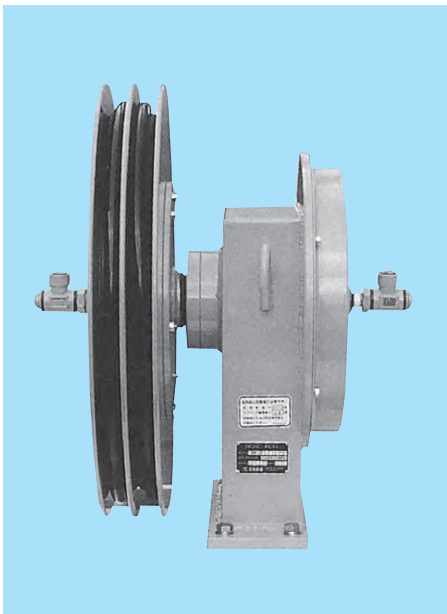

Vertical lift

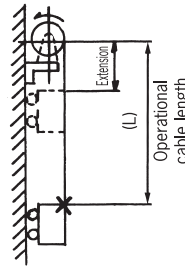

Vertical lift

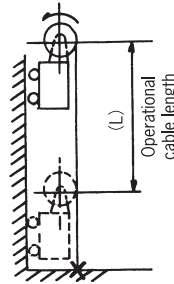

Horizontal stretch

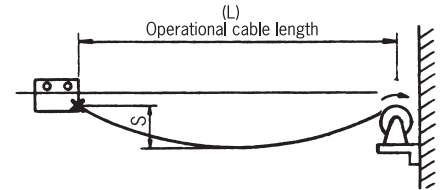
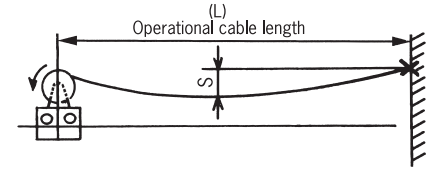

Application		Operational cable length (L)(m)										
		Hose	NWP140 1/4	NWP210 1/4	NWP140 3/8	NWP210 3/8	NWP140 1/2	NWP210 1/2	NWP140 3/4	NWP210 3/4	NWP140 1	NWP210 1
		Weight kg/m Outside dia. mm	12.3	12.4	15.0	16.7	19.1	20.4	27.9	28.7	35.4	35.9
Moving reel/Vertical lift Fixed reel/Vertical lift	Model											
	WORY-3S424-J	6	6									
	WORY-3S524-J	9	9									
	WORY-4S536-J			6	6							
	WORY-4S654-J			11	11							
	WORY-4S655-J					10	8.5					
	WORY-5S775-J					13	12					
WORY-6S8150-J							12	12				
Mobile or Stationary application/ Horizontal stretch	WORY-3S424-J	6	6									
	WORY-3S524-J	9	8									
	WORY-4S536-J			6	5							
	WORY-4S654-J			11	8							
	WORY-4S655-J					7	5.5					
	WORY-5S775-J					8	6					
	WORY-6S8150-J							7	6			

NOTE: 1. Calculated at following conditions:

- ① Fluid.....General Purpose Mineral Hydraulic Oil
- ② Working pressure.....less than 21.0MPa {210kgf/cm<sup>2</sup>}
- ③ Application.....Fixed reel/Vertical lift, Moving reel/Vertical lift, Mobile or Stationary application/Horizontal stretch
- ④ Maximum travel/lift.....less than 30mm/min

2. Deviations due to roller guides, non-straight cable payout, low ambient temperature, etc. are not calculated.

When selecting a model, please take into consideration of high mechanical stress and harsh environment conditions.

3. In case of Vertical lift, operational cable length (L) includes extension length.

4. In case of Horizontal stretch, Sag factor (S)=L x 6% includes extensions.

# Accessories (Suitable for CRL TYPE, HR TYPE)

CRL-2205~3A416W, CRL-4M424~4524F  
HR-2205~3A516W, HR-4524~4524T

CRL-5M636~7875F  
HR-4624W~6975T

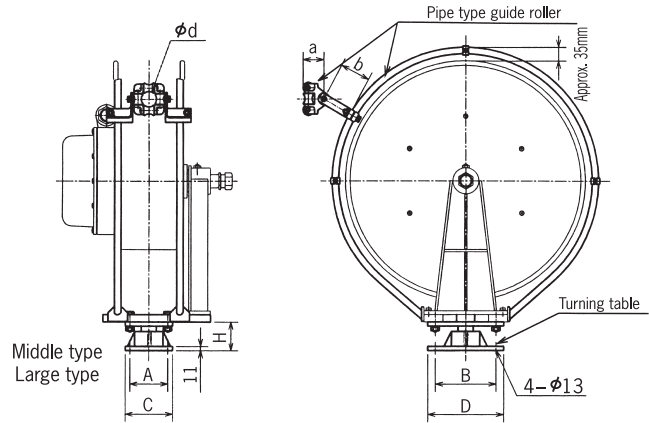
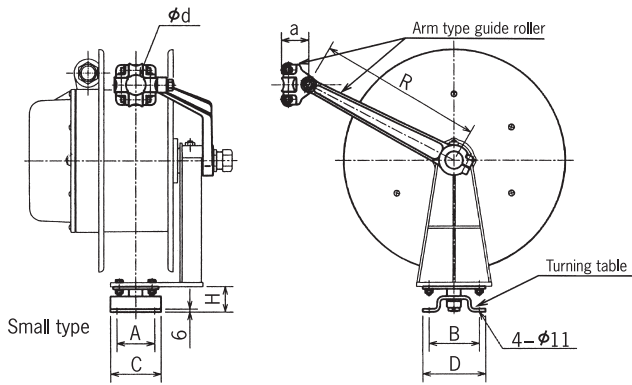

## Arm type guide roller

Type	Part No.	Available model	Dimensions (mm)		
			d	a	R
φ 30	LRP004984	CRL-2205 HR-2205	30	38	230
	LRP004987	CRL-2A205W, 2A210	30	38	230
	LRP004990	CRL-2305 HR-2305	30	38	260
	LRP004993	CRL-3316	30	38	260
	LRP004996	CRL-2A305W, 3A309W HR-2A305W	30	38	260
	LRP004999	CRL-3A316W	30	38	260
	LRP005002	CRL-3409	30	38	310
	LRP005005	HR-3416	30	38	310
	LRP005008	CRL-3A409W HR-3A409W	30	38	310
	LRP005011	CRL-3A416W HR-3A416W	30	38	310
LRP005017	HR-3A516W	30	38	360	
φ 40	LRP005020	CRL-4M424	40	54	325
	LRP005023	CRL-4424W~4424F	40	54	325
	LRP005026	HR-4524~4524T	40	54	365
	LRP005029	CRL-4524T, 4524F	40	54	365

Arm type guide roller is suitable for a guide of winding direction and as a cable stopper not to wind in a cable/hose completely when the operation is finished.

Please do not use guide roller to make a cable (hose) bend to change the winding direction.

NOTE: Recommended max outside diameters of cables (hoses) are as follows:

MAX25mm for Roller dia. 40

MAX35mm for Roller dia. 50

MAX50mm for Roller dia. 65

## Pipe type guide roller

Type	Part No.	Available model	Dimensions (mm)		
			d	a	b
φ 40	LRP010323	CRL-5M636	40	54	87
	LRP010325	CRL-5636W~5636F CRL-5655W, 5655T	40	54	87
	LRP010328	CRL-6M7112W	40	54	87
	LRP010331	CRL-6756F, 6756V CRL-6775W~6775F	40	54	87
	LRP010334	CRL-7875T, 7875F	40	54	87
	LRP010338	HR-4624W, 4624T	40	54	87
	LRP010339	HR-5736~5736T	40	54	87
	LRP010341	HR-6855~6855T	40	54	87
	LRP010344	HR-6975W, 6975T	40	54	87
φ 50	LRP010324	CRL-5M636	50	60	102
	LRP010326	CRL-5636W~5636F CRL-5655W, 5655T	50	60	102
	LRP010329	CRL-6M7112W	50	60	102
	LRP010332	CRL-6756F, 6756V CRL-6775W~6775F	50	60	102
	LRP010335	CRL-7875T, 7875F	50	60	102
	LRP010340	HR-5736~5736T	50	60	102
	LRP010342	HR-6855~6855T	50	60	102
	LRP010345	HR-6975W, 6975T	50	60	102
φ 65	LRP010327	CRL-5636W~5636F CRL-5655W, 5655T	65	69	118
	LRP010330	CRL-6M7112W	65	69	118
	LRP010333	CRL-6756F, 6756V CRL-6775W~6775F	65	69	118
	LRP010336	CRL-7875T, 7875F	65	69	118
	LRP010343	HR-6855~6855T	65	69	118
	LRP010346	HR-6975W, 6975T	65	69	118

## Roller

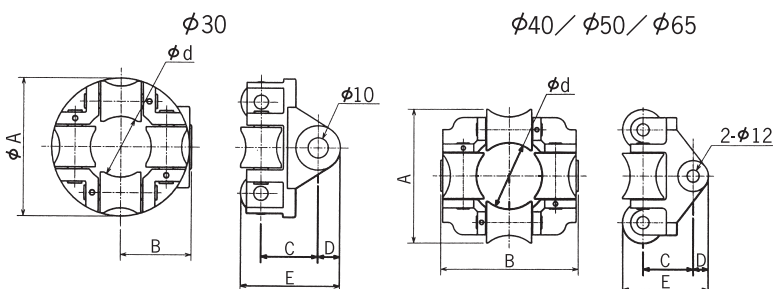

Type	Part No.	Dimensions (mm)					
		d	A	B	C	D	E
φ 30	LRP004972	30	68	35	28	11	49
φ 40	LRP004975	40	86	85	40	15	69
φ 50	LRP004978	50	105	114	44	15	75.5
φ 65	LRP004981	65	130	134	48.5	15	83.5

## L type bracket roller

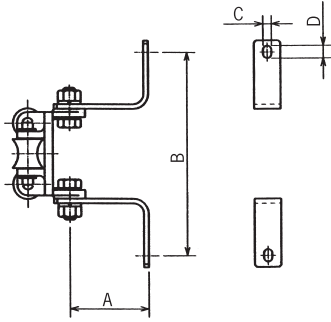

Code	Type	Part No.	Dimensions (mm)			
			A	B	C	D
540720	φ 40	LRP006524	75	193	8	12
540730	φ 50	LRP006525	90	193	8	17
540740	φ 65	LRP006526	105	192	10	20

## Cable grip

Used for fixing the direction of cable.

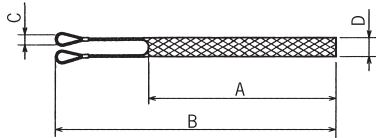

Code	Type	Part No.	Cable size (mm)	Dimensions (mm)				Capacity (kg)
				A	B	C	D	
540870	GH-23	P1R408555	23~29	230	345	16	23	200
540880	GH-33	P1R408562	30~39	300	450	22	30	300
540890	GH-40	P1R408554	40~51	400	600	22	40	400
540900	GH-52	P1R407224	52~69	520	780	28	52	600

(Reference)

## Ratchet device

Ratchet device holds the cable reel in place at certain points of payout in case of manual operations or the winding force is not required. Generally, ratchet device is used with guide roller. To cancel the ratchet, pulling out the cable (hose) 200mm~300mm in payout direction.

## Long arm type guide roller

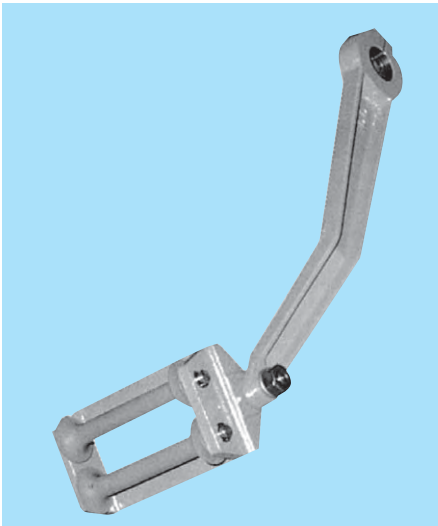

## Swivel base (SRB TYPE)

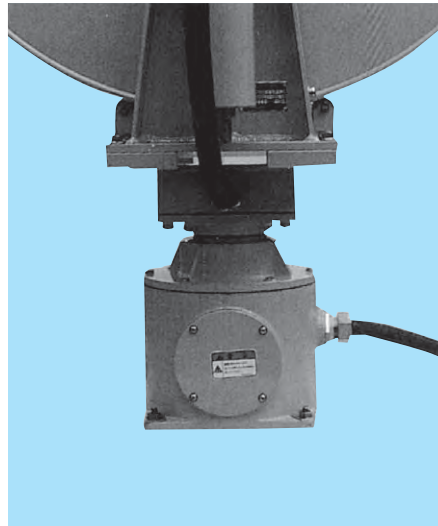

## Two-way payout guide roller



## Pivot base

Pivot base is used with a guide roller to alternate directions of cable payout. (Max rotation shall be within 300°) Swivel bases are available for applications that require a full 360° pivot.

Code	Size	Part No.	Available model	Dimensions (mm)					Mass (kg)
				A	B	C	D	H	
540820	S	LRP000471	CRL-2205~3A416W HR-2205~3A516W	75	100	100	125	50	1.4
540830	M	LRP000472	CRL-4M424~5655T HR-4524~5736T	100	160	125	200	75	5.8
540840	L	LRP000473	CRL-6756F~7875F HR-6855~6975T	120	200	150	240	100	6.8

NOTE : No upside down setting is allowed.

## Two-way payout guide roller

Suitable for applications where cable is paid out in two directions.

### GD-200R

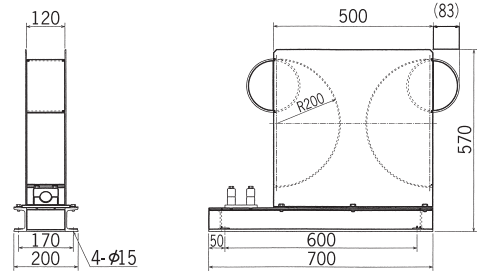

### GD-300R

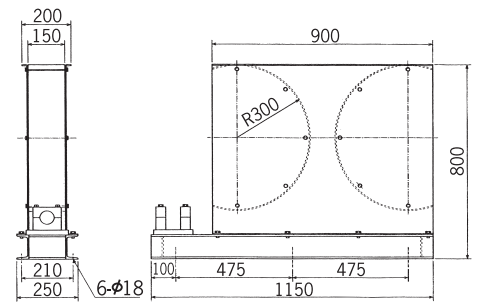

Type	Available model
05~16	CRL-2205~3A416W HR-2205~3A516W
24~55	CRL-4M424~5655T HR-4524~6855T



# Special specifications and applications

**Torque motor cable reel**



**Inverter-driven motor cable reel**



**Servomotor cable reel**

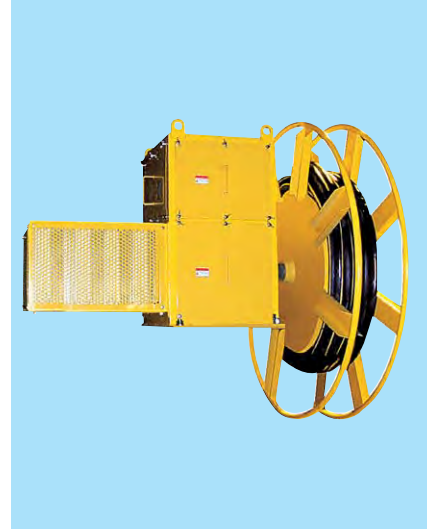

**Geared motor cable reel**



**Mono spiral cable reel**



**Wire reel (for stroke detection)**

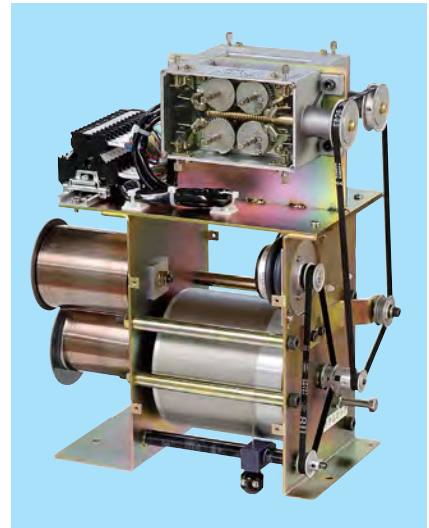

**Slip ring**

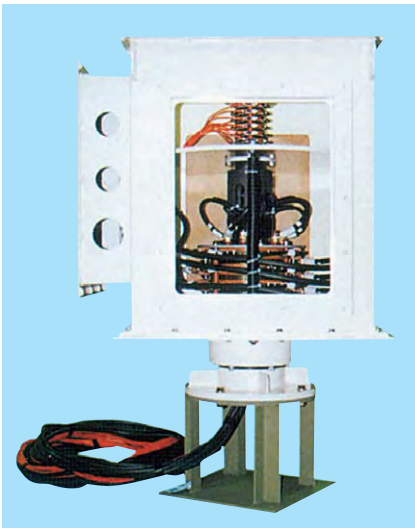

**Storage reel**



**Hose reel**

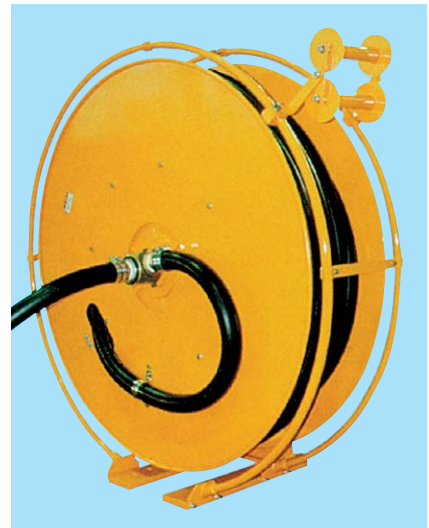



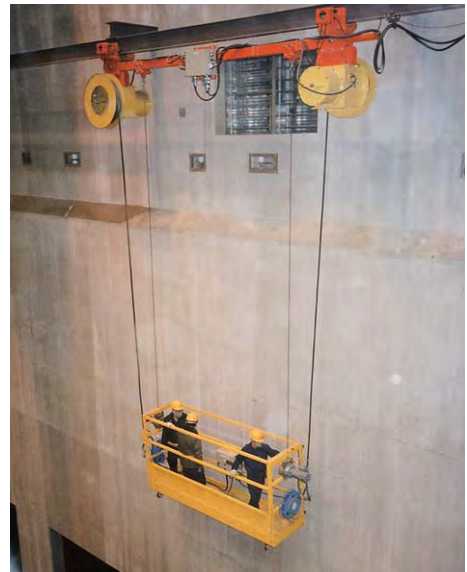

# Main components of a cable reel

## CRL TYPE

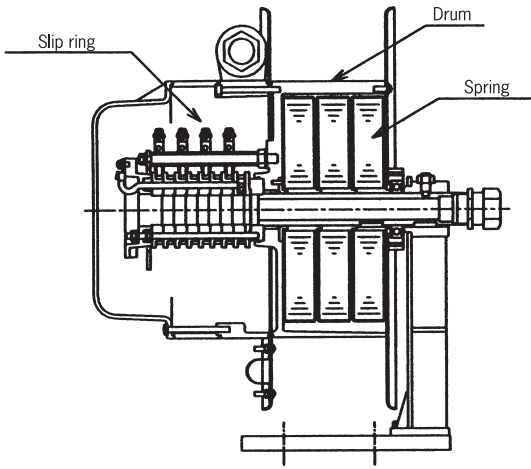

## CRE TYPE

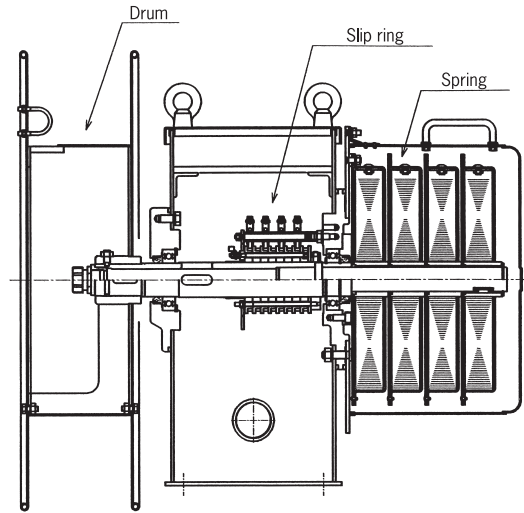

## CRH TYPE

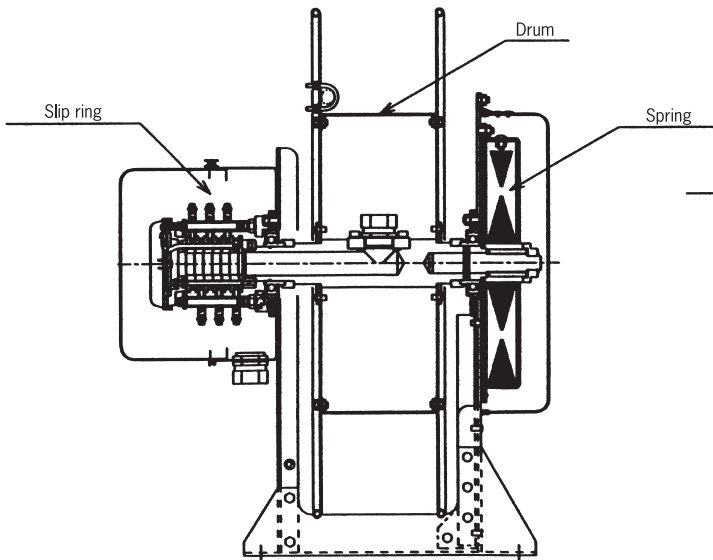

## HR TYPE

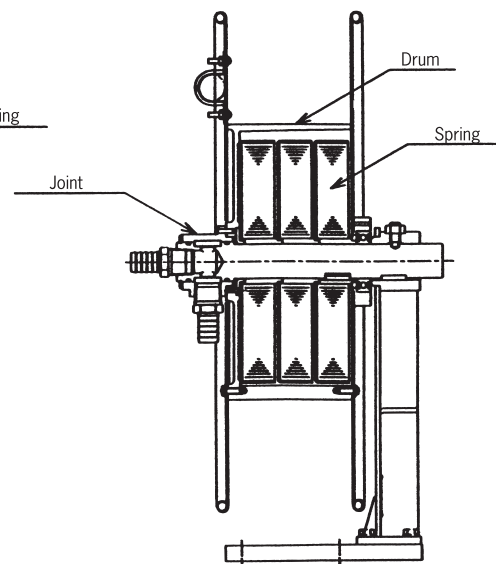

## TORQUE MOTOR TYPE

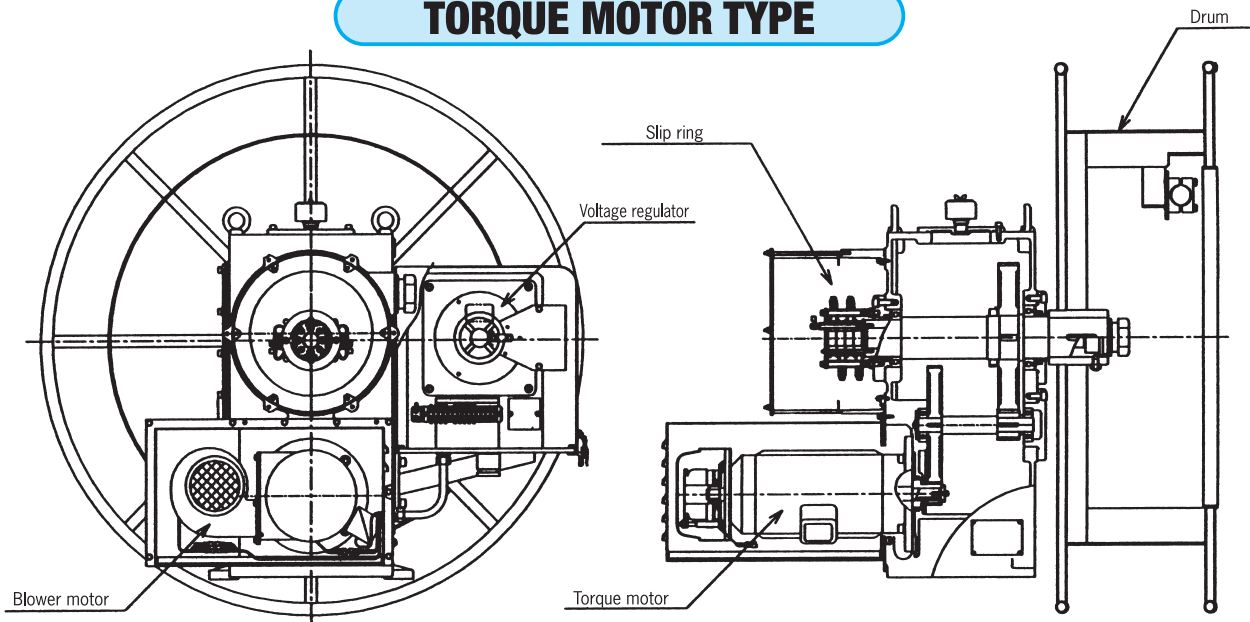



# Cable and hose data

## Cab-tire cable characteristics (JIS C 3327)

Type	Code	Max rated conductor temperature °C	Materials		Feature
			Insulation	Sheath	
Ethylene propylene rubber insulated chloroprene rubber sheathed cab-tire cable	PNCT	80	EP rubber	Chloroprene	Outside dia and mass are smaller than RNCT, and allowance current is larger.
Rubber insulated chloroprene rubber sheathed cab-tire cable	RNCT	60	Rubber	Chloroprene	
Rubber cab-tire cable	CT	60	Rubber	Rubber	Good cold resistance but bad oil resistance
Vinyl cab-tire cable	VCT	60	Vinyl	Vinyl	Oil and chemical resistance are relatively good

NOTE: Model name is indicated with the numerical code as prefix.

For example :2PNCT: Ethylene propylene rubber insulated chloroprene rubber sheathed cab-tire cable

## Structure (structure reinforcement)

Model	Structure, application
Type 1	For simple applications, rubber cab-tire cable only
Type 2	Standard type, for a mild environment
Type 3	Strong type. Reinforced tape in the sheath
Type 4	Heavy-duty type. Reinforced tape in the sheath and rubber between conductors

## Allowable current value of cab-tire cable (unit:A)

Number of conductor Cable cross-section (mm <sup>2</sup> )	2 C		3 C		4 C		6 C	
	CT	RNCT	CT	RNCT	CT	RNCT	CT	RNCT
1.25	15	20	13	18	12	16	10	15
2.0	20	28	18	24	16	21	15	20
3.5	30	40	25	35	20	31	18	28
5.5	35	51	30	45	25	40	20	37
8.0	45	64	40	55	35	49	30	45
14.0	65	89	55	78	50	69	45	61
22.0	85	120	75	105	70	93	65	81
30.0	105	135	90	120	85	110	-	-
38.0	120	165	105	135	100	125	-	-
50.0	145	190	125	155	120	145	-	-
60.0	165	215	145	187	135	170	-	-
80.0	200	263	175	228	160	209	-	-
100.0	230	303	205	263	185	241	-	-

NOTE: 1. Top values indicate CT / RNCT and bottom values indicate PNCT in each column.

2. Ambient temperature 30°C

## Three-phase induction motor and cable cross-section

Rated output kw	Full load current (A)		Cable cross-section (mm <sup>2</sup> )	
	200V	400V	200V	400V
0.4	2.0	1.0	2.0	1.25
0.75	3.6	1.8	2.0	1.25
1.5	6.6	3.3	2.0	1.25
2.2	9.5	4.8	2.0	1.25
3.7	15.0	7.5	3.5	1.25
5.5	24.0	12.0	5.5	3.5
7.5	32.0	16.0	8.0	3.5
11.0	46.0	23.0	14.0	5.5
15.0	64.0	32.0	22.0	8.0
19.0	80.0	40.0	30.0	8.0
22.0	92.0	46.0	38.0	14.0
30.0	122.0	61.0	50.0	22.0
37.0	150.0	75.0	60.0	22.0
45.0	164.0	83.0	80.0	30.0
55.0	204.0	102.0	125.0	38.0

NOTE: When selecting a cable, please refer to the chart of max length of cable

## Chart of max length of cable Three-phase, three-wire system (voltage drop 2V)

Cable cross-section (mm <sup>2</sup> )	Current (A)														
	2.0	3.5	5.5	8	14	22	30	38	50	60	80	100	125	150	200
Max length of cable (m)															
3	43	68	115												
5	26	41	69	104											
7	18	29	49	75	127										
10	13	20	34	52	89	140									
15		14	23	35	59	93	123								
20		10	17	26	44	70	93	118							
25			14	21	36	56	74	95	122						
30			11	17	30	47	62	79	102						
35				15	25	40	53	68	87	109					
40				13	22	35	46	59	76	95	126				
45					20	31	41	53	68	84	112				
50					18	28	37	47	61	76	100				
60					15	23	31	39	51	63	84	107			
70						20	26	34	44	54	72	92	114		
80						18	23	30	38	47	63	80	100		
90							21	26	34	42	56	71	89	109	
100								24	30	38	50	64	80	98	125
120									25	32	42	53	67	82	104
140										27	36	46	57	70	89
150										25	33	43	53	65	83
160											31	40	50	61	78
180											28	36	44	54	69
200												32	40	49	63

### Remarks

- When voltage drop is 4V or 6V, the length of cable will be twice or three times larger than the length in the chart.
- Calculated at following conditions:
  - Balanced load
  - Power factor
  - Copper cable
- 

Length of cable (m)	Voltage drop(%)
Less than 60	Less than 2
Less than 120	Less than 4
Less than 200	Less than 5

## 2PNCT (JIS C 3327)

Number of conductors Cable cross-section (mm <sup>2</sup> )	2 C		3 C		4 C		6 C		8 C		10 C		12 C		16 C		20 C	
	Outside dia. mm	Mass kg/m	Outside dia. mm	Mass kg/m	Outside dia. mm	Mass kg/m	Outside dia. mm	Mass kg/m	Outside dia. mm	Mass kg/m	Outside dia. mm	Mass kg/m	Outside dia. mm	Mass kg/m	Outside dia. mm	Mass kg/m	Outside dia. mm	Mass kg/m
1.25	9.8	0.14	10.5	0.175	11.5	0.195	13.5	0.26	16.0	0.36	18.0	0.41	18.5	0.455	21.0	0.57	23.0	0.7
2.0	11.0	0.175	11.5	0.2	12.5	0.245	14.5	0.33	17.0	0.445	19.5	0.515	20.0	0.57	22.0	0.725	25.0	0.89
3.5	12.5	0.245	13.0	0.29	14.5	0.355	17.0	0.485	20.0	0.66	23.0	0.765	23.0	0.86	26.0	1.09	29.0	1.36
5.5	14.5	0.35	15.5	0.415	17.0	0.515	21.0	0.72	24.0	1.0	27.0	1.13	28.0	1.28	31.0	1.66	35.0	2.04
8.0	16.0	0.435	17.0	0.525	18.5	0.655	23.0	0.93	27.0	1.27								
14.0	18.5	0.64	20.0	0.795	22.0	1.0	27.0	1.42	32.0	1.96								
22.0	25.0	1.07	27.0	1.33	29.0	1.67												
(30.0)	27.0	1.34	29.0	1.67	32.0	2.1												
38.0	30.0	1.63	32.0	2.02	35.0	2.55												
(50.0)	34.0	2.1	36.0	2.62	40.0	3.32												
60.0	37.0	2.52	39.0	3.15	44.0	4.02												
(80.0)	43.0	3.47	46.0	4.32	51.0	5.5												
100.0	47.0	4.2	50.0	5.27	56.0	6.72												

NOTE:( ) shows quasi-standard size.

## VCT531XX • VCT531UX (Excerpt from a certain cable manufacturer's catalog)

Number of conductors Cable cross-section (mm <sup>2</sup> )	2 C		3 C		4 C		6 C		8 C		10 C		12 C		16 C		20 C	
	Outside dia. mm	Mass kg/m	Outside dia. mm	Mass kg/m	Outside dia. mm	Mass kg/m	Outside dia. mm	Mass kg/m	Outside dia. mm	Mass kg/m	Outside dia. mm	Mass kg/m	Outside dia. mm	Mass kg/m	Outside dia. mm	Mass kg/m	Outside dia. mm	Mass kg/m
0.75	8.8	0.105	9.2	0.12	9.9	0.145	12.0	0.195	18.0	0.39	19.5	0.47	19.0	0.455	21.0	0.565	23.0	0.68
1.25	9.6	0.125	10.5	0.145	11.5	0.175	13.5	0.24	19.0	0.48	21.0	0.595	20.5	0.58	23.0	0.71	25.0	0.87
2.0	10.5	0.155	11.0	0.18	12.0	0.215	14.5	0.31	21.0	0.6	23.0	0.73	22.0	0.72	24.5	0.9	27.0	1.11
3.5	12.0	0.215	13.0	0.265	14.0	0.33	16.5	0.465	24.5	0.89	27.0	1.09	26.0	1.1	29.0	1.39	32.0	1.71
5.5	14.5	0.315	15.0	0.385	16.5	0.48	20.0	0.69	29.5	1.33	33.0	1.64	31.5	1.65	35.0	2.05	39.0	2.56
8.0	16.5	0.425	17.5	0.53	19.5	0.665	23.5	0.96										
14.0	20.5	0.655	22.0	0.825	24.0	1.04	29.5	1.54										
22.0	26.0	1.07	28.0	1.33	30.5	1.67	37.5	2.48										
30.0	28.5	1.33	30.5	1.67	33.5	2.12	41.5	3.16										
38.0	31.5	1.65	34.0	2.08	37.5	2.67	46.0	3.94										
50.0	34.5	2.01	37.0	2.53	41.0	3.23												
60.0	37.5	2.4	40.0	3.06	44.5	3.9												
80.0	42.5	3.14	45.5	4.02	50.5	5.12												
100.0	46.5	3.84	50.0	4.91	55.5	6.24												

NOTE:1.VCT531XX applies to cable with 2 to 6 conductors, and VCT531UX applies from 8 to 20 conductors.

2.The cable has resistance to oil, water and weather

## 2TC-RH (Excerpt from a certain cable manufacturer's catalog)

Number of conductors Cable cross-section (mm <sup>2</sup> )	2 C		3 C		4 C		6 C		8 C		10 C		12 C		16 C		20 C		30 C	
	Outside dia. mm	Mass kg/m	Outside dia. mm	Mass kg/m	Outside dia. mm	Mass kg/m	Outside dia. mm	Mass kg/m	Outside dia. mm	Mass kg/m	Outside dia. mm	Mass kg/m	Outside dia. mm	Mass kg/m	Outside dia. mm	Mass kg/m	Outside dia. mm	Mass kg/m	Outside dia. mm	Mass kg/m
1.25	11.5	0.16	12.0	0.185	12.5	0.215	14.5	0.295	17.0	0.395	19.0	0.5	22.0	0.59	22.0	0.635	24.0	0.775	29.0	1.11
2.0	12.0	0.185	12.5	0.215	13.5	0.26	15.5	0.36	18.0	0.485	21.0	0.625	23.0	0.715	24.0	0.795	26.0	0.975	31.0	1.38
3.5	13.0	0.25	14.0	0.295	15.0	0.36	17.5	0.515	21.0	0.7	24.0	0.91	26.0	1.03	27.0	1.19	30.0	1.45	35.0	2.08
5.5	15.5	0.35	16.5	0.43	18.0	0.535	22.0	0.775	25.0	1.06	30.0	1.27	29.0	1.37	33.0	1.76	36.0	2.19	43.0	3.11
8.0	18.0	0.5	19.0	0.61	21.0	0.765														

NOTE:The sizes above are finished diameter in standard.

## Popular cables (our recommendation)

- F-2PNCT • Reinforced type
- 2TC-RH
- RE-2PNCT
- KT-3PNCT
- 3PNCT-B

## Hose data (Excerpt from a certain cable manufacturer's catalog)

Type Size (in)	Acetylene hose Water hose			Air hose			Oil resistance hose			High-pressure hose			High-pressure hose		
	Outside dia. mm	Mass kg/m	Normal pressure MPa(kgf/cm <sup>2</sup> )	Outside dia. mm	Mass kg/m	Normal pressure MPa(kgf/cm <sup>2</sup> )	Outside dia. mm	Mass kg/m	Normal pressure MPa(kgf/cm <sup>2</sup> )	Outside dia. mm	Mass kg/m	Normal pressure MPa(kgf/cm <sup>2</sup> )	Outside dia. mm	Mass kg/m	Normal pressure MPa(kgf/cm <sup>2</sup> )
6(1/4)	13.5	0.155	0.2 {2}	15.5	0.215	1.5 {15}	16.5	0.25	1.4 {14}	13.5	0.23	7 {70}	14.5	0.31	14 {140}
8(5/16)	15.0	0.175	0.2 {2}	17.5	0.275	1.5 {15}	18.5	0.3	1.2 {12}	—	—	—	—	—	—
9(3/8)	16.5	0.205	0.2 {2}	18.5	0.29	1.5 {15}	20.5	0.35	1.0 {10}	17.5	0.36	7 {70}	17.5	0.38	14 {140}
12(1/2)	19.0	0.235	0.5 {5}	22.5	0.41	1.0 {10}	24.5	0.47	1.0 {10}	20.5	0.46	7 {70}	23.0	0.78	14 {140}
15(5/8)	23.0	0.325	0.5 {5}	26.0	0.5	1.0 {10}	29.0	0.63	1.0 {10}	24.0	0.56	7 {70}	26.5	0.9	14 {140}
19(3/4)	27.0	0.435	0.5 {5}	30.0	0.625	1.0 {10}	32.0	0.71	0.8 {8}	28.0	0.69	7 {70}	29.5	1.07	14 {140}
25(1)	34.0	0.61	0.5 {5}	37.5	0.9	1.0 {10}	39.5	0.98	0.8 {8}	35.5	1.02	7 {70}	40.0	2.14	14 {140}
32(1 1/4)	43.0	0.99	0.5 {5}	47.0	1.35	1.0 {10}	46.0	1.2	0.8 {8}	45.0	1.63	7 {70}	48.0	2.75	14 {140}

NOTE:1.Other hoses not listed above are available to suit the pressure. (Vinyl hose for low pressure, nylon hose for high pressure, etc.)

2.Diameters and weights listed above may vary with cable different manufactures.

## Type F hose series for standard hydraulic oil (Excerpt from a certain cable manufacturer's catalog)

Model	Size	Inside dia. mm	Outside dia. mm	Normal pressure MPa(kgf/cm <sup>2</sup> )	Bending radius mm	Mass kg/m
F-15-06	6	6.3	12.7	1.5{15}	75	0.13
F-15-09	9	9.5	15.9	1.5{15}	95	0.175
F-15-12	12	12.7	19.7	1.5{15}	120	0.25
F-15-19	19	19.0	30.0	1.5{15}	175	0.585
F-15-25	25	25.4	37.0	1.5{15}	225	0.785
F-15-32	32	31.8	44.8	1.5{15}	285	1.075
F-15-38	38	38.1	51.1	1.5{15}	330	1.23
F-15-50	50	50.8	65.4	1.5{15}	430	1.72

Model	Size	Inside dia. mm	Outside dia. mm	Normal pressure MPa(kgf/cm <sup>2</sup> )	Bending radius mm	Mass kg/m
F-35-06	6	6.3	13.0	3.5{35}	75	0.14
F-35-09	9	9.5	16.5	3.5{35}	100	0.195
F-35-12	12	12.7	20.3	3.5{35}	125	0.275
F-35-19	19	19.0	32.6	3.5{35}	195	0.755
F-35-25	25	25.4	39.2	3.5{35}	240	0.96
F-35-32	32	31.8	46.0	3.5{35}	295	1.1
F-35-38	38	38.1	52.3	3.5{35}	370	1.32
F-35-50	50	50.8	66.2	3.5{35}	435	1.905

## Type NWP hose series for standard hydraulic oil (Excerpt from a certain cable manufacturer's catalog)

Model	Size	Inside dia. mm	Outside dia. mm	Normal pressure MPa(kgf/cm <sup>2</sup> )	Bending radius mm	Mass kg/m
NWP140	6	6.3	12.3	14{140}	45	0.175
NWP140	9	9.5	15.0	14{140}	50	0.22
NWP140	12	12.7	19.1	14{140}	60	0.34
NWP140	15	15.9	24.0	14{140}	95	0.62
NWP140	19	19.0	27.9	14{140}	110	0.79
NWP140	25	25.4	35.4	14{140}	140	1.17
NWP140	32	31.8	43.5	14{140}	240	1.75
NWP140	38	38.1	50.5	14{140}	290	2.41
NWP140	50	50.8	64.5	14{140}	370	3.55

Model	Size	Inside dia. mm	Outside dia. mm	Normal pressure MPa(kgf/cm <sup>2</sup> )	Bending radius mm	Mass kg/m
NWP210	6	6.3	12.4	21{210}	45	0.18
NWP210	9	9.5	16.7	21{210}	60	0.36
NWP210	12	12.7	20.4	21{210}	80	0.49
NWP210	15	15.9	24.1	21{210}	110	0.64
NWP210	19	19.0	28.7	21{210}	130	0.93
NWP210	25	25.4	35.9	21{210}	180	1.38
NWP210	32	31.8	44.3	21{210}	280	1.98
NWP210	38	38.1	51.4	21{210}	330	2.8
NWP210	50	50.8	65.9	21{210}	430	4.6

# **CABLE REEL HOSE REEL**

## **ENDO ENDO KOGYO CO., LTD.**

3-14-7, Akibacho, Tsubame, Niigata, Japan  
TEL : +81-256-62-5131 FAX. +81-256-62-5772

<http://www.endo-kogyo.co.jp>



ISO9001 JP97/010458  
SCOPE : Head office, Plant



ISO14001 JP10/070952  
SCOPE : Head office, Plant

## **ENDO ENDO KOGYO INDIA PVT. LTD.**

101, First Floor, Aditya Towers  
LullaNagar, Off Kondhwa Road, Pune - 411 040  
TEL : +91-86-00042752 Mail. [info@endo-india.co.in](mailto:info@endo-india.co.in)

<http://www.endo-india.co.in>

\*Items shown in this catalogue are subject to change without notice. Please note we have no responsibility for missing and fault on this printing.

Printed in March 2019 EC-80C 500 ®